



Multi-functional Flow Control Valve for Water Treatment Systems

F135 (17610T)

F137 (17606T)

WENZHOU RUNXIN MANUFACTURING MACHINE CO., LTD.

ADD: NO.169, RUNXIN ROAD, SHANFU TOWN, WENZHOU, ZHEJIANG, CHINA.

Tel: 0086-577-88630038, 88576512, 85956057 Fax: 0086-577-88633258

<http://www.run-xin.com> Email:sales@run-xin.com

Rev.A. 2303

User Manual





Please read this manual in details
before using this valve and keep it properly
in order to consult in the future

0WRX.466.748

MODEL: F135/17610T-F137/17606T

Before the valve put into use, please fill in the below content so as to help us to refer in the future.

The Program Type Setting (Operation by professional)

When all symbols light on, press and hold  and  buttons for 5 seconds to enter the menu of valve model selection. Please set the program type in accordance with the product type.

Softener System Configuration

Tank Size: Dia. _____ mm; Height _____ mm;

Resin Volume _____ L; Brine Tank Capacity _____ L;

Hardness of Raw Water _____ mmol/L;

Pressure of Inlet Water _____ MPa;

Control Valve Model _____; Number _____;

The Specification of Drain Line Flow Control _____;

Injector No. _____.

Water Source: Ground-water ; Filtered Ground-water ; Tap Water ; Other _____.

Parameter Set

Parameter	Unit	Factory Default	Actual Value
Time of Day	Hour: Minute	Current Time	
Control Mode A-01/02	/	A-01	
Unit Mode HU-01/02/03	/	HU-01	
Water Treatment Capacity	m ³	80.00	
Resin Volume	L	50L	
Feed Water Hardness	Mmol/L	1.2mmol/L	
Regeneration Factor	/	0.65	
Fast Rinse Time	min	10:00	
Backwash Time	min	10:00	
Brine& Slow Rinse Time	min	70:00	
Brine Refill Time	min	05:00	
Maximum Interval Regeneration Days	D	30	
Signal Output Mode	/	b-01	

● If there is no special requirement when product purchase, for 17610T, there is no DLFC, and standard injector is 4#. For 17606T, there is no DLFC, and standard injector is 3#.

Catalogue

Notice	3
1. Product Overview	4
1.1. Main Application & Applicability	4
1.2. Product Characteristics	4
1.3. Service Condition	5
1.4. Product Structure and Technical Parameters	6
1.5. Installation	8
2. Basic Setting & Usage	14
2.1. The Function of PC Board	14
2.2. Basic Setting & Usage	15
3. Applications	20
3.1. Softener Flow Chart	20
3.2. The Function and Connection of PC Board	21
A. Signal Output Connector	22
B. Pressure Relief Connector	24
C. Remote Handling Connector	24
3.3. System Configuration and Flow Rate Curve	25
3.4. Parameter Settlement	28
3.5. Parameter Enquiry and Setting	30
3.6. Trial Running	33
3.7. Trouble-Shooting	34
3.8. Assembly & Parts	36
4. Warranty Card	44

Notice

- To ensure normal operation of the valve, please consult with professional installation or repairing personnel before use it.
- If there are any of pipeline engineering and electric works, there must be finished by professional at the time of installation.
- Do not use the control valve with the water that is unsafe or unknown quality.
- Depending on the changing of working environment and water requirement, each parameter of softener should be adjusted accordingly.
- When the water treatment capacity is too low, please check the resin. If the reason is shortage of resin, please add; if the resin is turn to reddish brown or broken, please replace.
- Test water periodically to verify that system is performing satisfactorily.
- Sodium used in the water softening process should be considered as part your overall dietary salt intake. Contact doctor if you are on a low sodium diet.
- Ensure that there is solid salt all the time in the brine tank in the course of using, when this valve is used for softening. The brine tank should be added the crystalline coarse salt only, at least 99.5% pure, forbidding use the small salt.
- Do not put the valve near the hot resource, high humidity, corrosive, intense magnetic field or intense vibrations environment. And do not leave it outside.
- Forbidden to carry the injector body. Avoid using injector body as support to carry the system.
- Forbidden to use the brine tube or other connectors as support to carry the system.
- Please use this product under the water temperature between 5~50℃, water pressure 0.2~0.6MPa. Failure to use this product under such conditions voids the warranty.
- If the water pressure exceeds 0.6MPa, a pressure reducing valve must be installed in front of the water inlet. While, if the water pressure is under 0.15MPa, a booster pump must be installed in front of the water inlet.
- It is suggested to install PPR pipe, corrugated pipe or UPVC pipe, instead of TTLSG pipe.
- Do not let children touch or play, because careless operations may cause the procedure changed.
- When the attached cables or transformer of this product are broken, they must be changed to the one that is from our factory.

1. Product Overview

1.1 Main Application & Applicability

- Used for softening or demineralization water treatment systems
- Be suitable for ion exchange equipment
- Boiler softening water system
- RO pretreatment softening system, etc.

1.2 Product Characteristics

● Simple structure and reliable sealing

It adopts hermetic head faces with high degree pottery and corrosion resistance for opening and closing; Using U1, U2 service tank for switching, it combines with Regeneration such as Standby, Fast Rinse, Backwash, Brine & Slow Rinse, Brine Refill.

● Meter type regeneration, single valve with double tanks to achieve continuous water supply.

● Manual function

Realize regeneration immediately by pressing  at any time.



● Long outage indicator

If outage overrides 3 days, the time of day indicator 12:12 will flash to remind people to reset new time of day. It's no need to reset parameters. The process will continue to work after power on.

● LED Dynamic Display Screen

The stripes on dynamic screen flash, which indicates the control valve is in service, otherwise, it is in regeneration cycle.

● Buttons lock

No operations to buttons within 1 minute, keyboard is locked automatically. Before operation, press and hold  and  buttons for 5 seconds to unlock. This function can avoid incorrect operation.

● Signal output connector

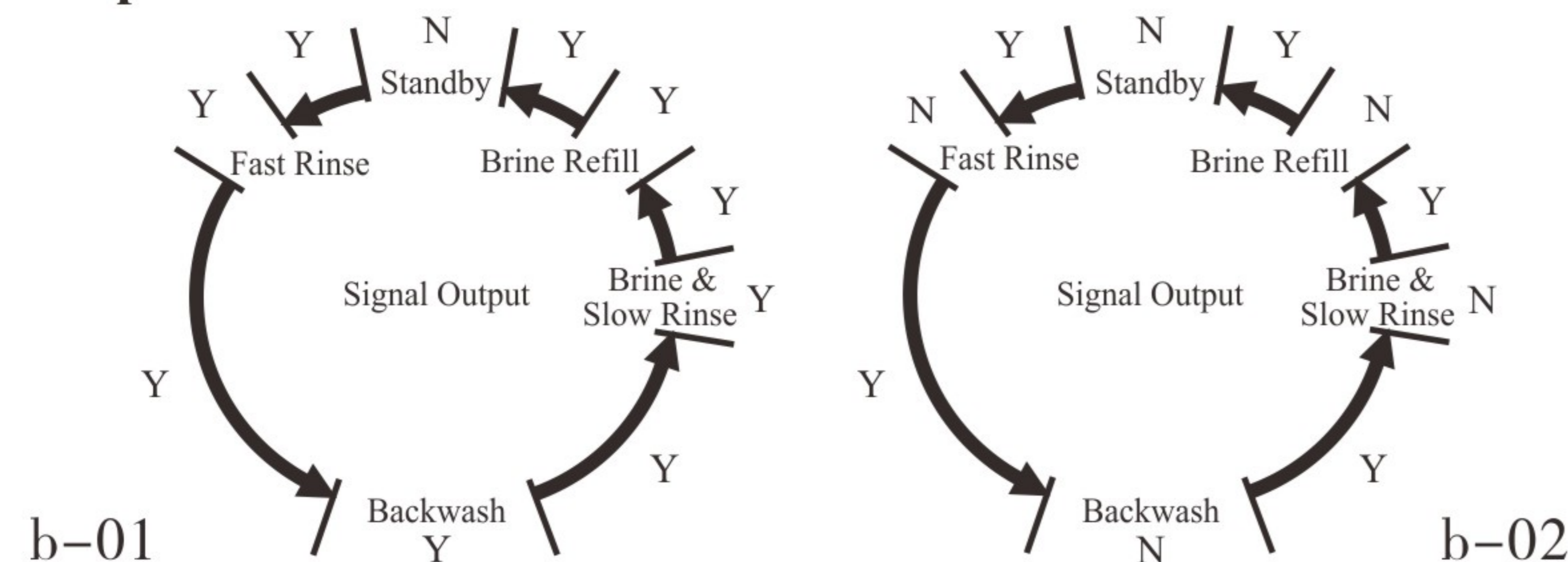

There is a signal output connector on main control board. It is for controlling external wiring (Refer to Figures from Figure 3-2 to Figure 3-6).

There are two kinds of output modes. b-01 Mode: Turn on at the start of regeneration and shut off at the end of regeneration; b-02 Mode: Signal available only at intervals of each status.

● Remote Handling Connector

This connector can receive external signal, used together with PLC, and computer etc. to control the valve. (Application refer to Figure 3-8)

● Pressure Relief Connector

The valve will cut off feeding water to drain line when it switches in regeneration cycles (Same as signal output b-02). Thus in some water treatment system, e.g. Deep Well, one booster pump is installed on the inlet to increase the system water feeding pressure, this cut-off will cause pressure on inlet rising too fast to damage the valve. Pressure relief connector can be used to avoid this problem. (Application refer to Figure 3-7)

● Maximum Interval Regeneration Days

Under the situation of service reaching the setting days and the volume not yet, it could enter regeneration process forcibly when current time is same as regeneration time.

● All parameters can be modified

According to the water quality and usage, the parameters in the process can be adjusted.

1.3 Service Condition

Runxin Valve should be used under the below conditions:

Items		Requirement
Working conditions	Water pressure	0.2MPa~0.6MPa
	Water temperature	5°C~50°C
Working environment	Environment temperature	5°C~50°C
	Relative humidity	≤95% (25°C)
	Electrical facility	AC100~240V/50~60Hz
Inlet water quality	Water turbidity	< 5FTU
	Water hardness	First Grade Na+ < 6.5mmol/L; Second Grade Na+ < 10mmol/L
	Free chlorine	< 0.1mg/L
	Iron ²⁺	< 0.3mg/L
	CODMn	< 2mg/L (O ₂)

MODEL: F135/17610T-F137/17606T

1.4 Product Structure and Technical Parameters

Structure of 17610T:

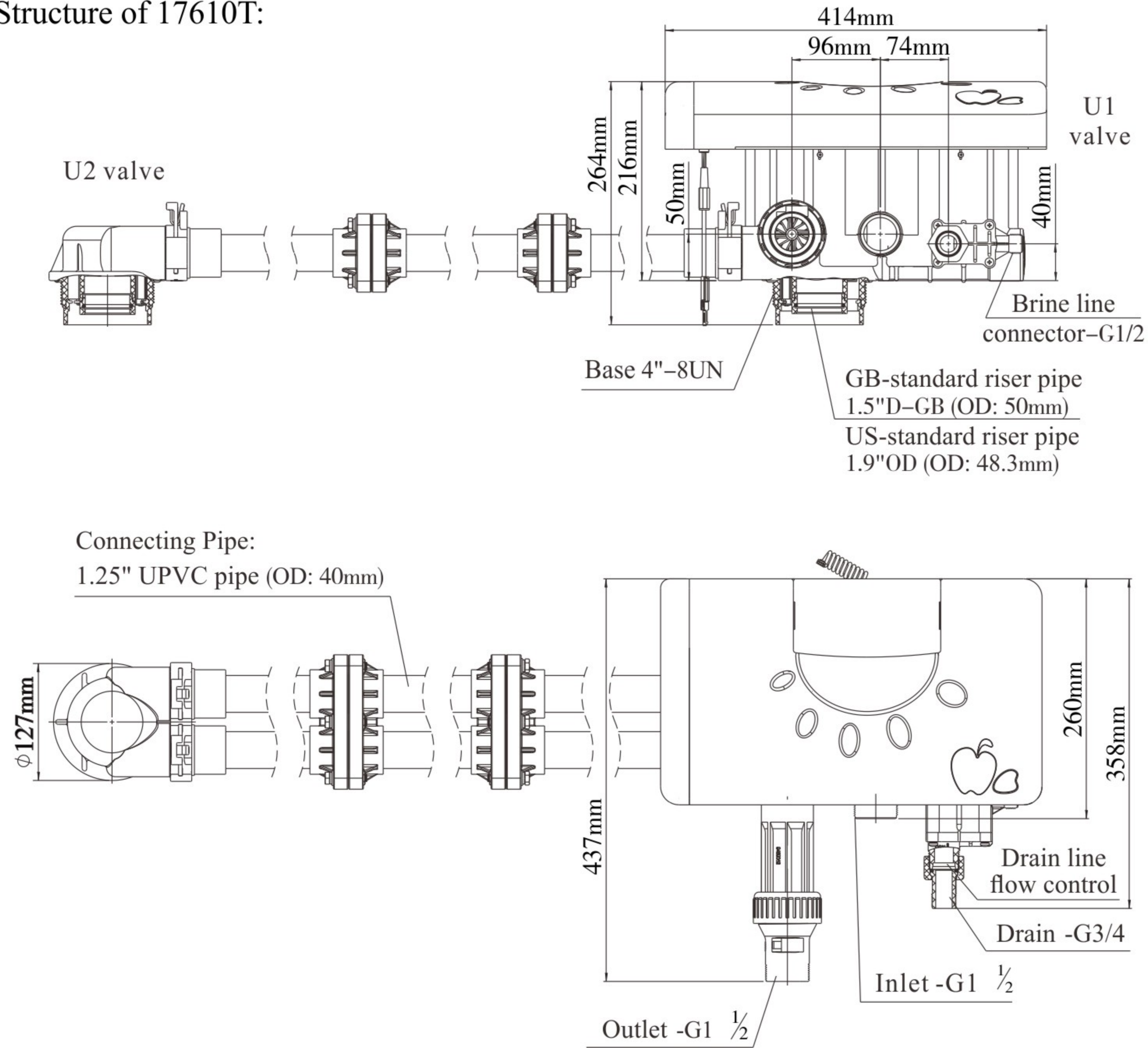

Transformer output is DC24V, 1.5A

Model	Connector size					Flow Rate m ³ /h @0.2MPa	Remark
	Inlet/outlet	Drain	Brine line connector	Base	Riser pipe		
17610T	1.5" M	3/4" M	1/2" M	4" -8UN	1.5"D-GB (OD:50mm) or 1.9"OD (OD:48.3mm)	10	Meter type Top-mounted installation (down-flow regeneration)

M-Male F-Female

MODEL: F135/17610T-F137/17606T

Structure of 17606T:

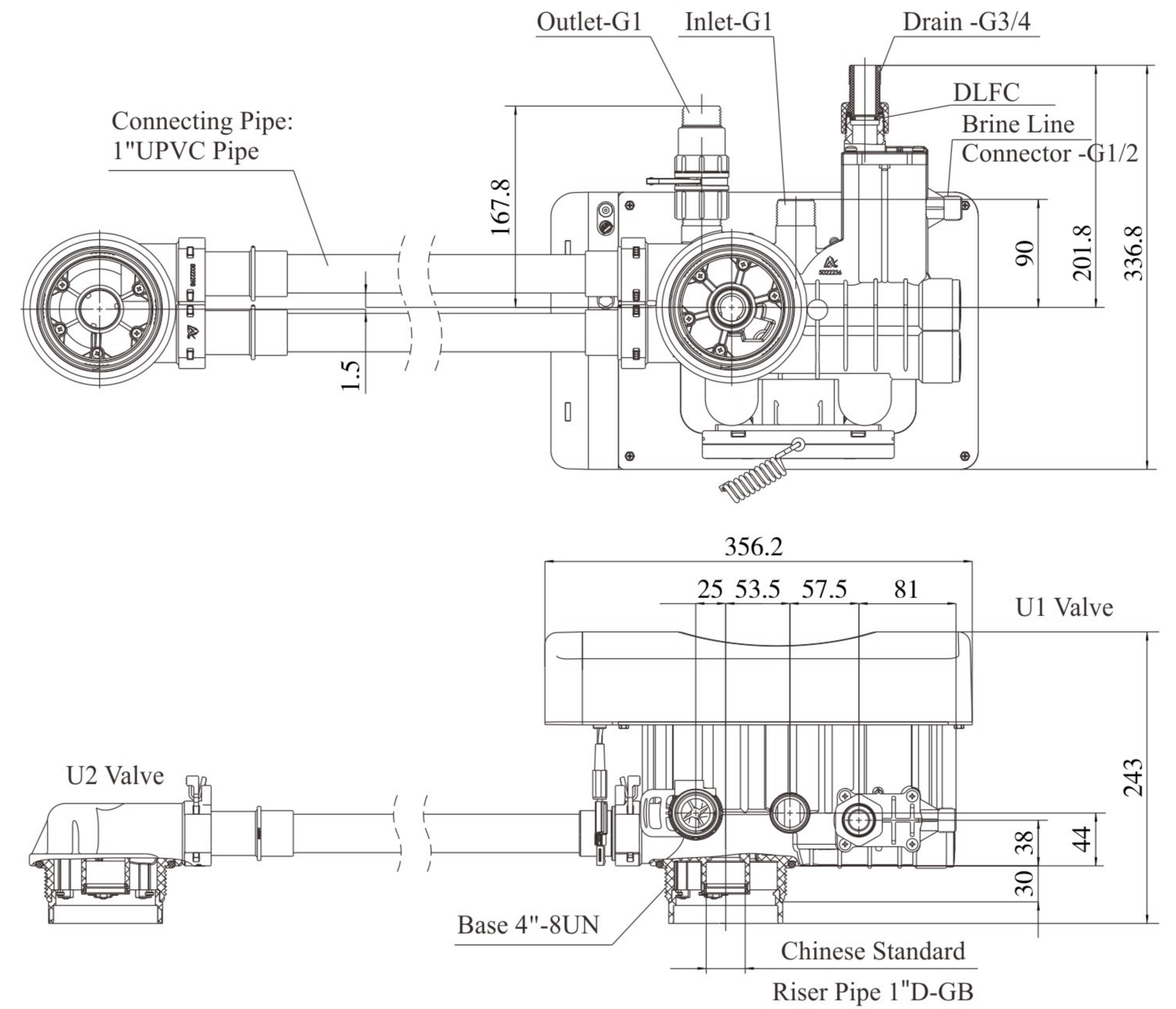

Technical Parameters of 17606T

Transformer output is DC12V, 1.5A

Model	Connector size					Flow Rate m ³ /h @0.2MPa	Remark
	Inlet/outlet	Drain	Brine line connector	Base	Riser pipe		
17606T	1" M	3/4" M	1/2" M	4" -8UN	1"D-GB (OD 32mm)	6	Meter Type, Top-mounted installation, down-flow regeneration.

M-Male F-Female

1.5 Installation

A. Installation notice

Before installation, read all those instructions completely. Then obtain all materials and tools needed for installation.

The installation of product, pipes and circuits should be accomplished by professional to ensure the product can operate normally.

Perform installation according to the relative pipeline regulations and the specification of Water Inlet, Water Outlet, Drain Outlet, Brine Line Connector.

B. Device location

1. The softener should be located close to drain.
2. Ensure the unit is installed in enough space for operating and maintenance.
3. Brine tank needs to be close to softener.
4. The unit should be kept away from the heater, and not be exposed outdoor. Sunshine or rain will cause the system damage.
5. Please avoid to install the system in one acid/alkaline, magnetic or strong vibration circumstance, because above factors will cause the system disorder.
6. Do not install the filter or softener, drain pipeline in circumstance which temperature may drop below 5°C, or above 50°C.
7. Install the system in the place where with the minimum loss in case of water leaking.

C. Install U1 and U2 valve

Install control valve:

As Figure 1 shows (take 17610T as example)

1. Glue the U1 valve riser pipe to the bottom strainer and put it into resin tank, cut off the exceeding tube out of tank top opening and make external rounding.
2. Fill specified quantity of resin to tank.
3. Screw top strainer into U1 valve.
4. Insert the riser pipe into U1 valve and screw tight control valve.
5. Install the U2 valve to resin tank as shown in above steps.

Notice:

- The length of riser pipe should be neither higher 4mm nor lower 5mm than tank top opening height, and its top end should be rounded to avoid damage of O-ring inside the valve.

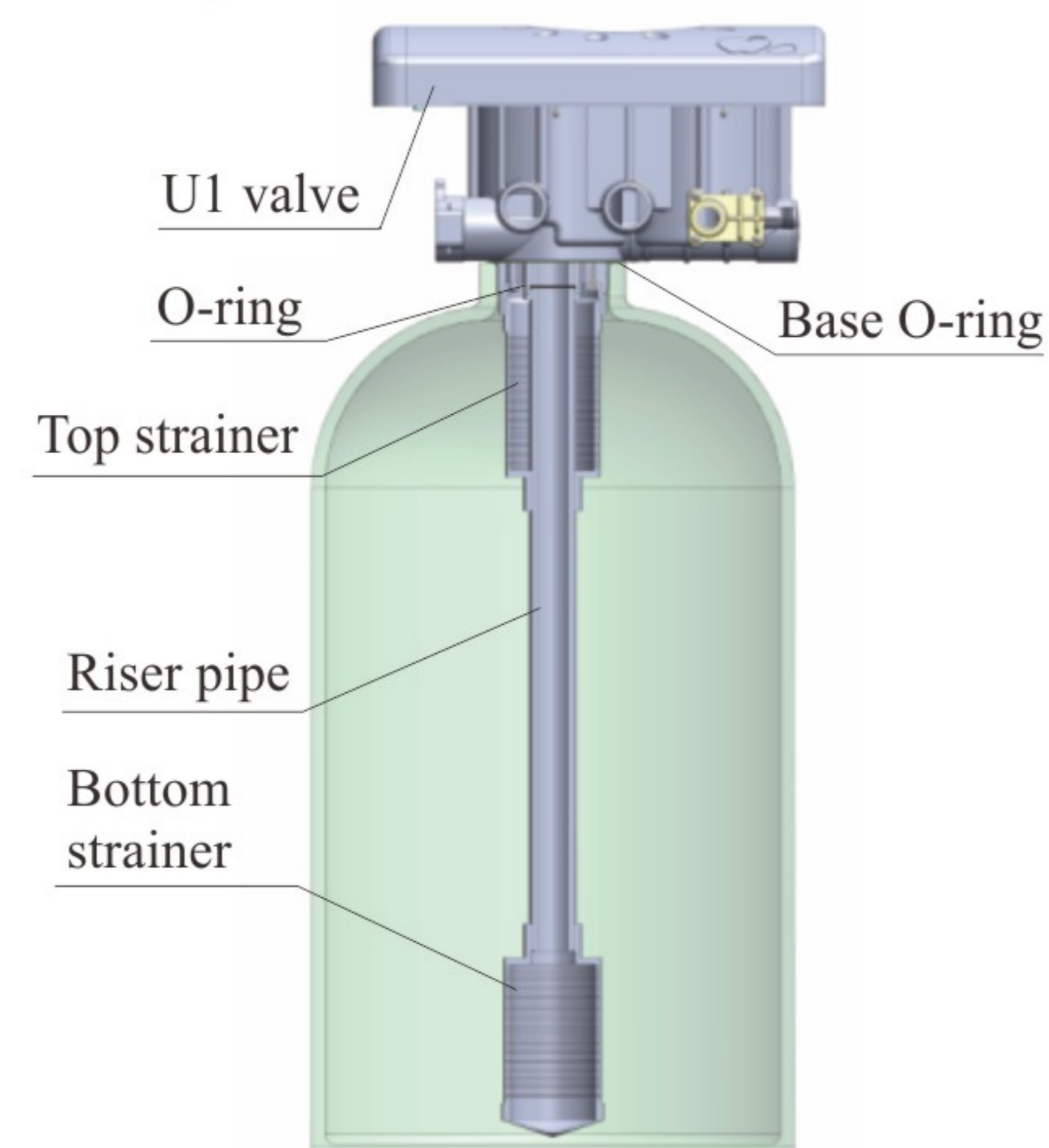

Figure 1

- Avoid filling floccules substance together with resin in the resin tank.
- Avoid O-ring inside control valve falling out while rotating it on the tank.

17610T Connecting pipe installation:

Note: Please determine the distance between the two tanks according to the following installation steps before filling the filter material.

1. As Figure 2-1-1 shows, glue the pipe, flange A and joint, and then install the corresponding O-ring into the joint and flange A respectively (2 pieces in total).

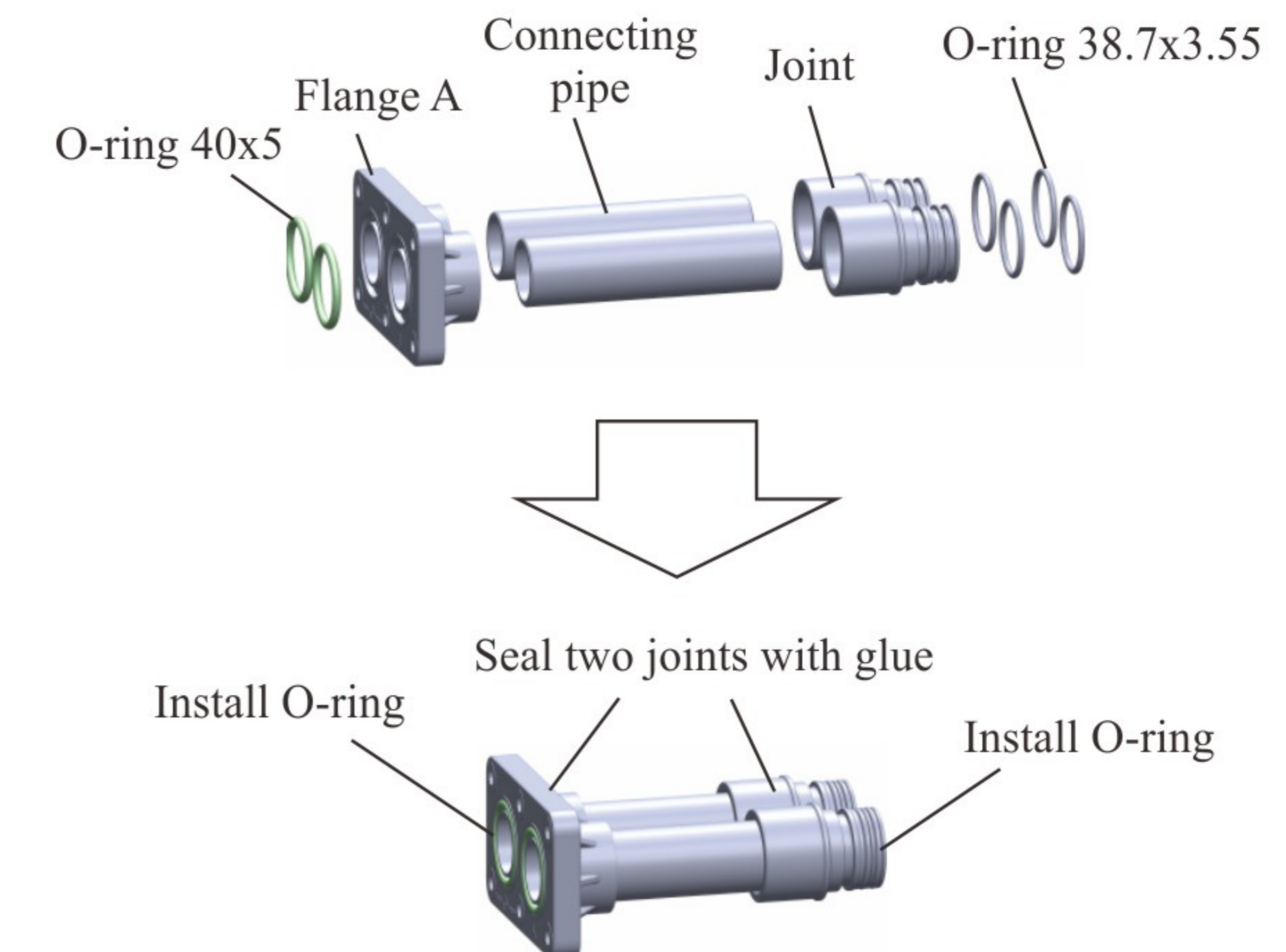

Figure 2-1-1

2. As Figure 2-1-2 shows, glue the pipe, flange B (1 piece in total).

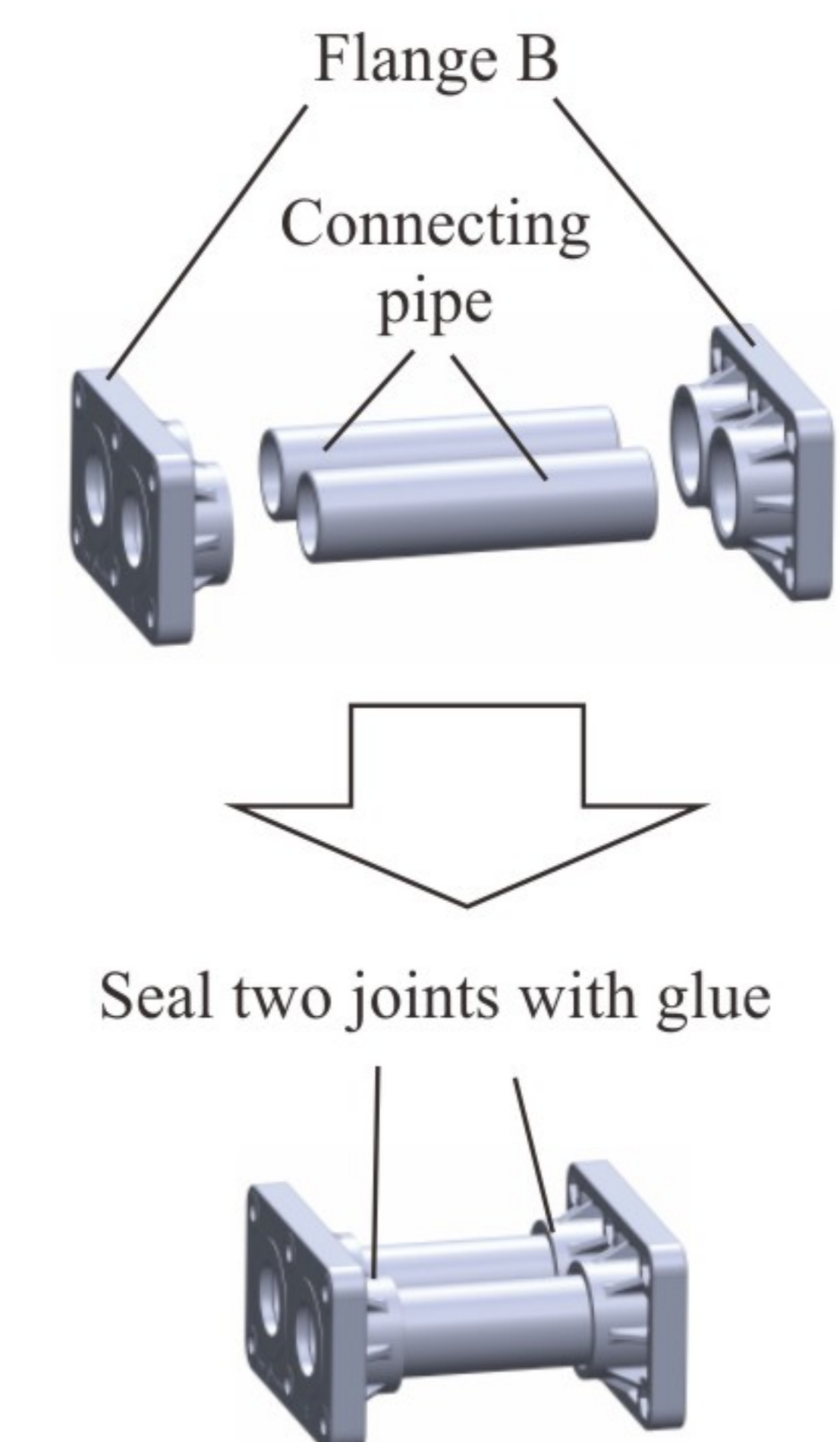

Figure 2-1-2

3. As Figure 2-1-3 shows, insert the connecting pipe which is completed in step 1 into U1 valve and U2 valve, and fix with clip. **(The installation space shall be reserved for the connecting pipe which is completed in Step 2).**

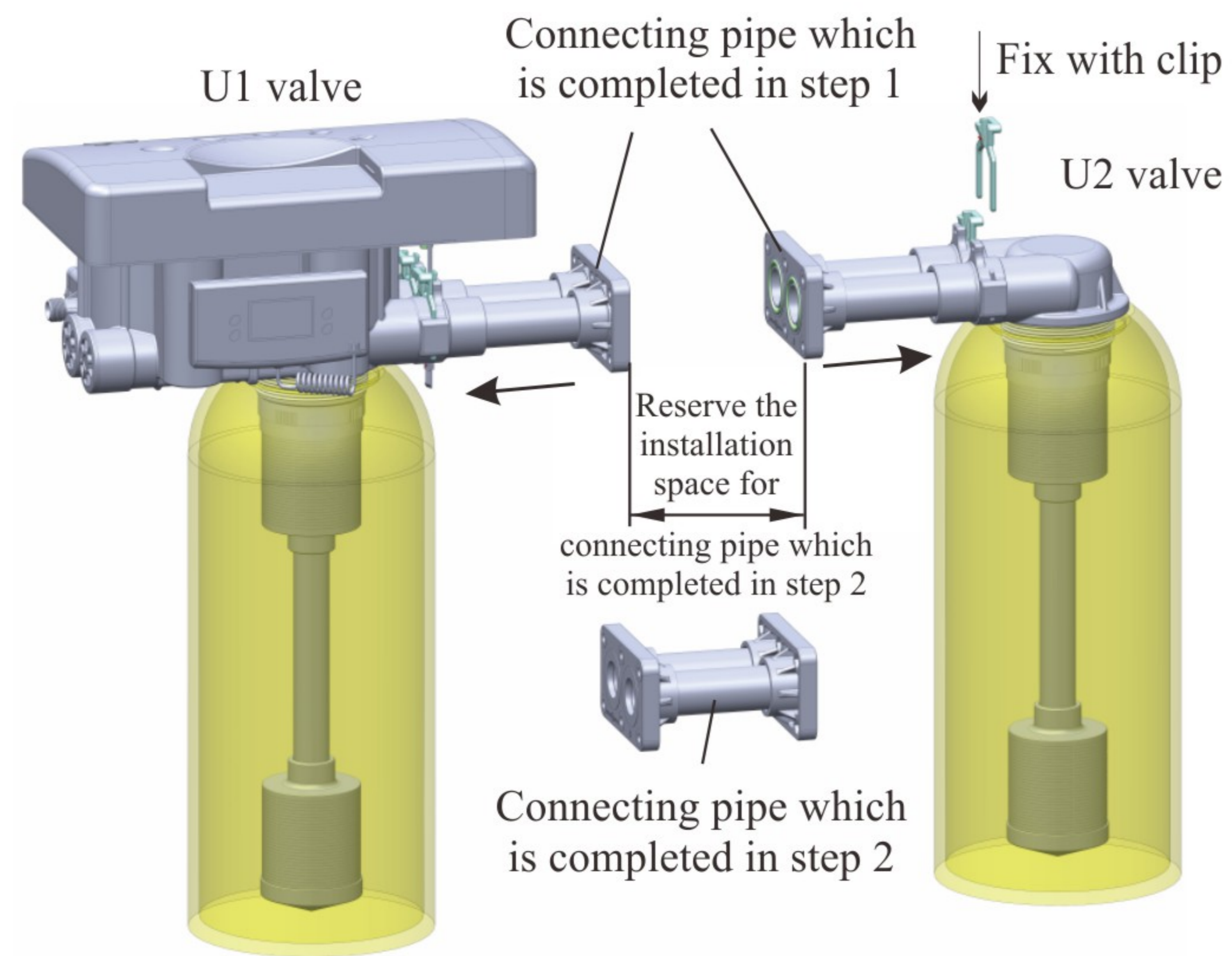

Figure 2-1-3

4. As Figure 2-1-4 shows, tighten the flange connection of connecting pipe with hexagon-head bolt and hexagon nut.

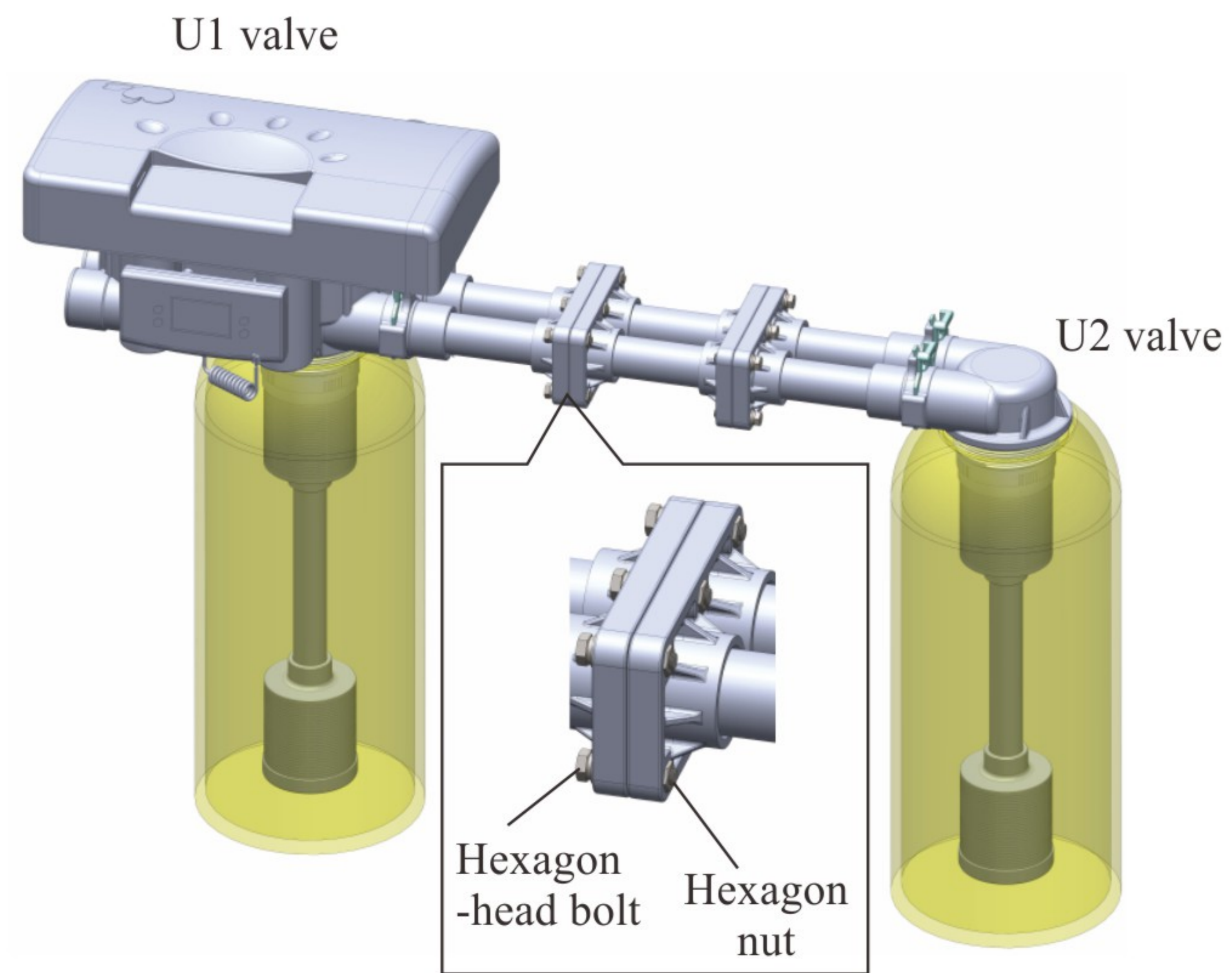

Figure 2-1-4

17606T Connecting pipe installation:

Note: Please determine the distance between the two tanks according to the following installation steps before filling the filter material.

1. As Figure 2-2-1 shows, glue the pipe, short and long joints, and then install O-rings into two joints respectively (2 pieces in total).

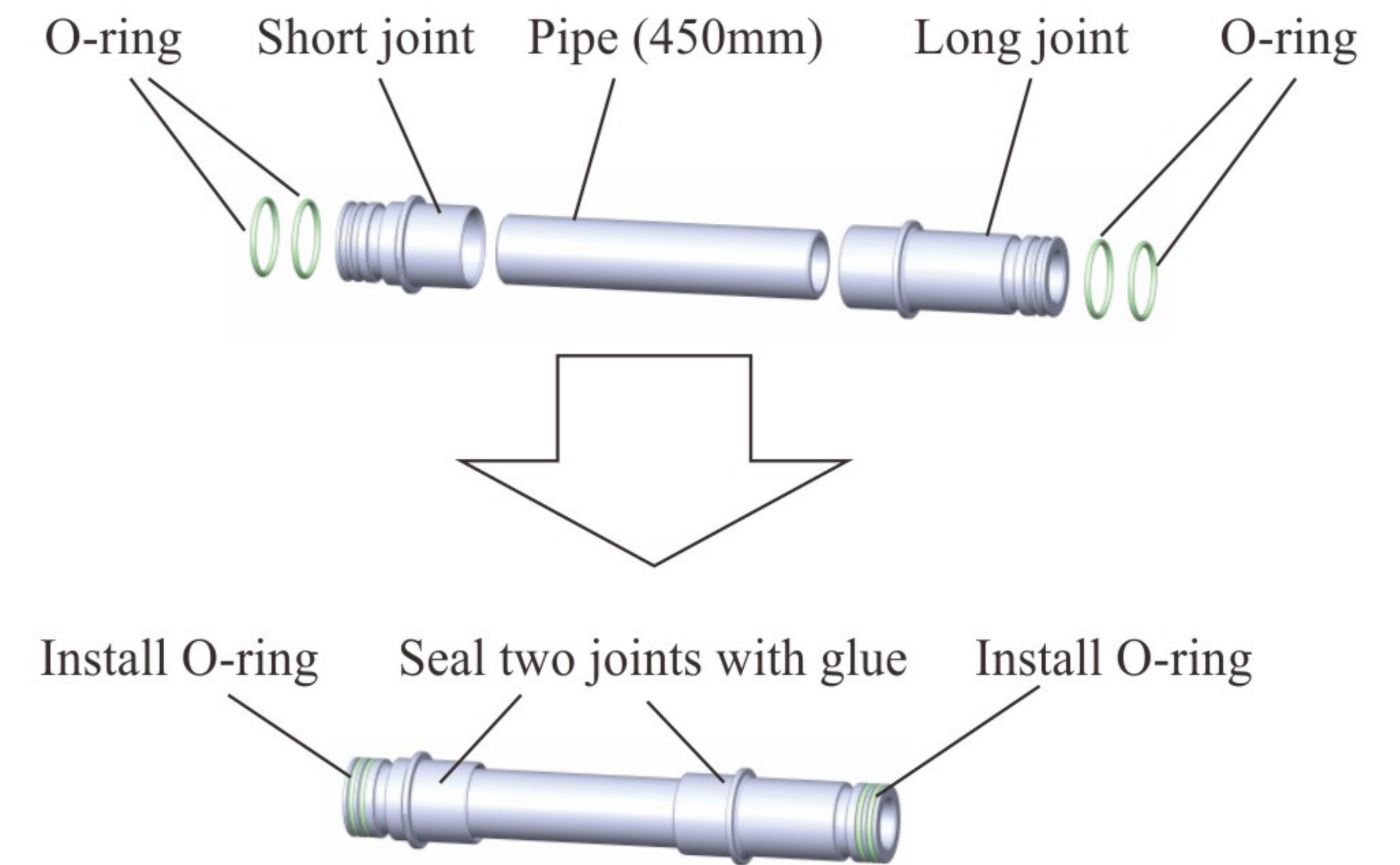

Figure 2-2-1

2. As Figure 2-2-2 shows, insert one end of the long joint of the connecting pipe completed in step 1 to the U2 valve.

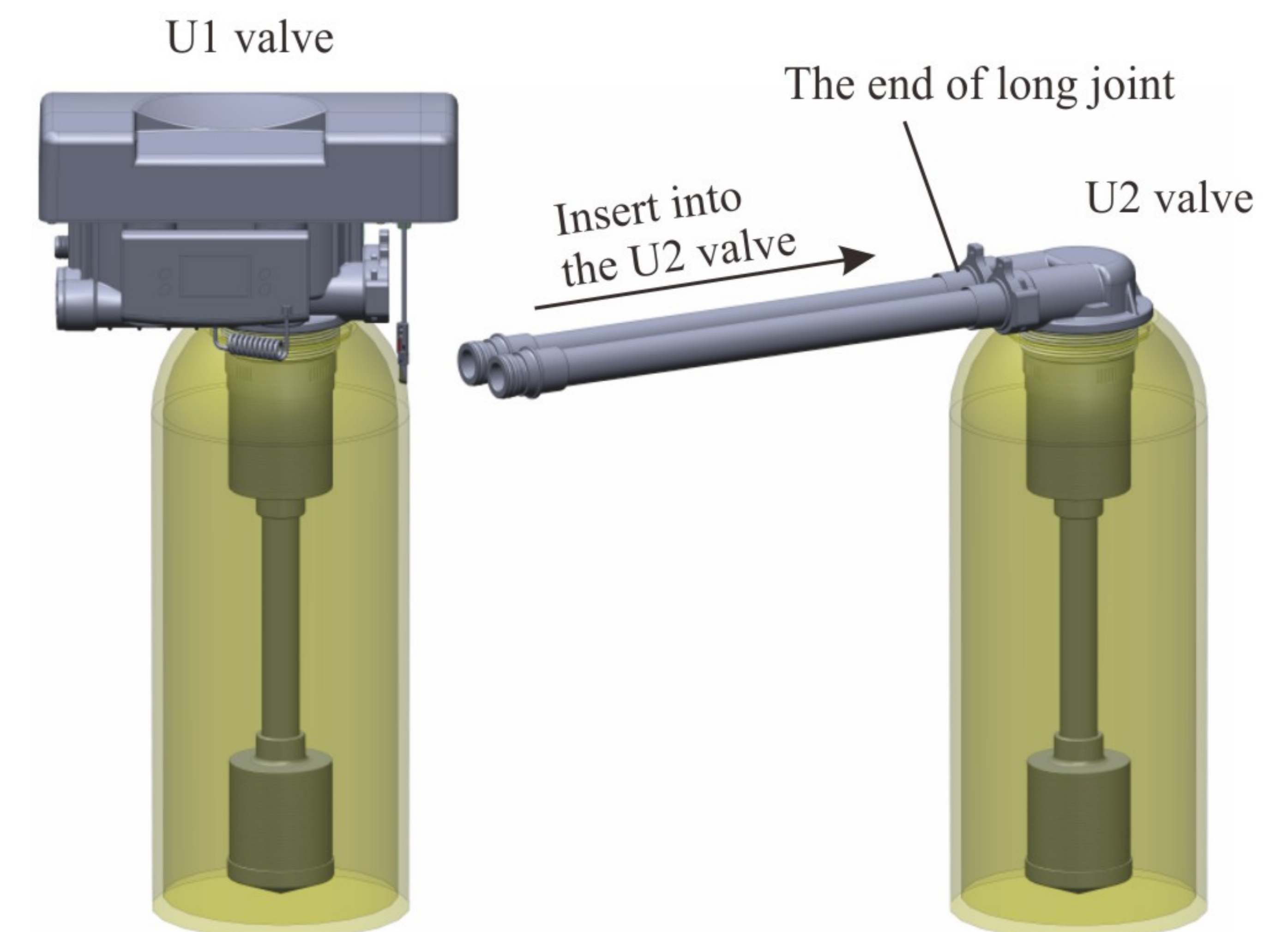

Figure 2-2-2

3. As Figure 2-2-3 shows, screw tightly U2 valve so that the connecting pipe is aligned with the U1 valve connecting pipe hole, and the gap is about 8.2mm;

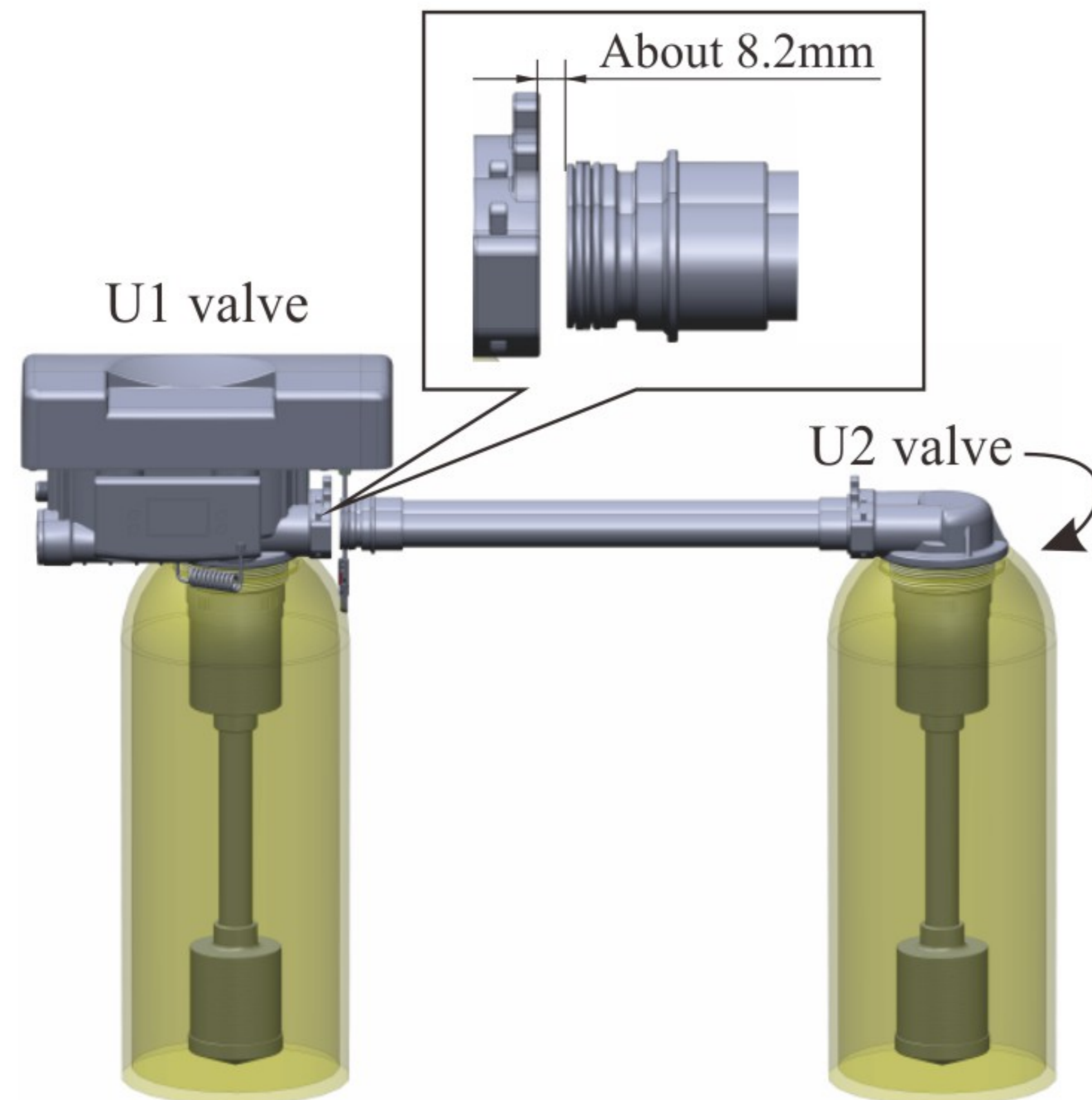

Figure2-2-3

4. As Figure 2-2-4 shows, insert the connecting pipe to the U1 valve, and then insert the clips of U1 valve and U2 valve to fix the connecting pipe (if the reserved gap in Step 3 is not 8.2mm, the clips of U2 valve couldn't be inserted!).

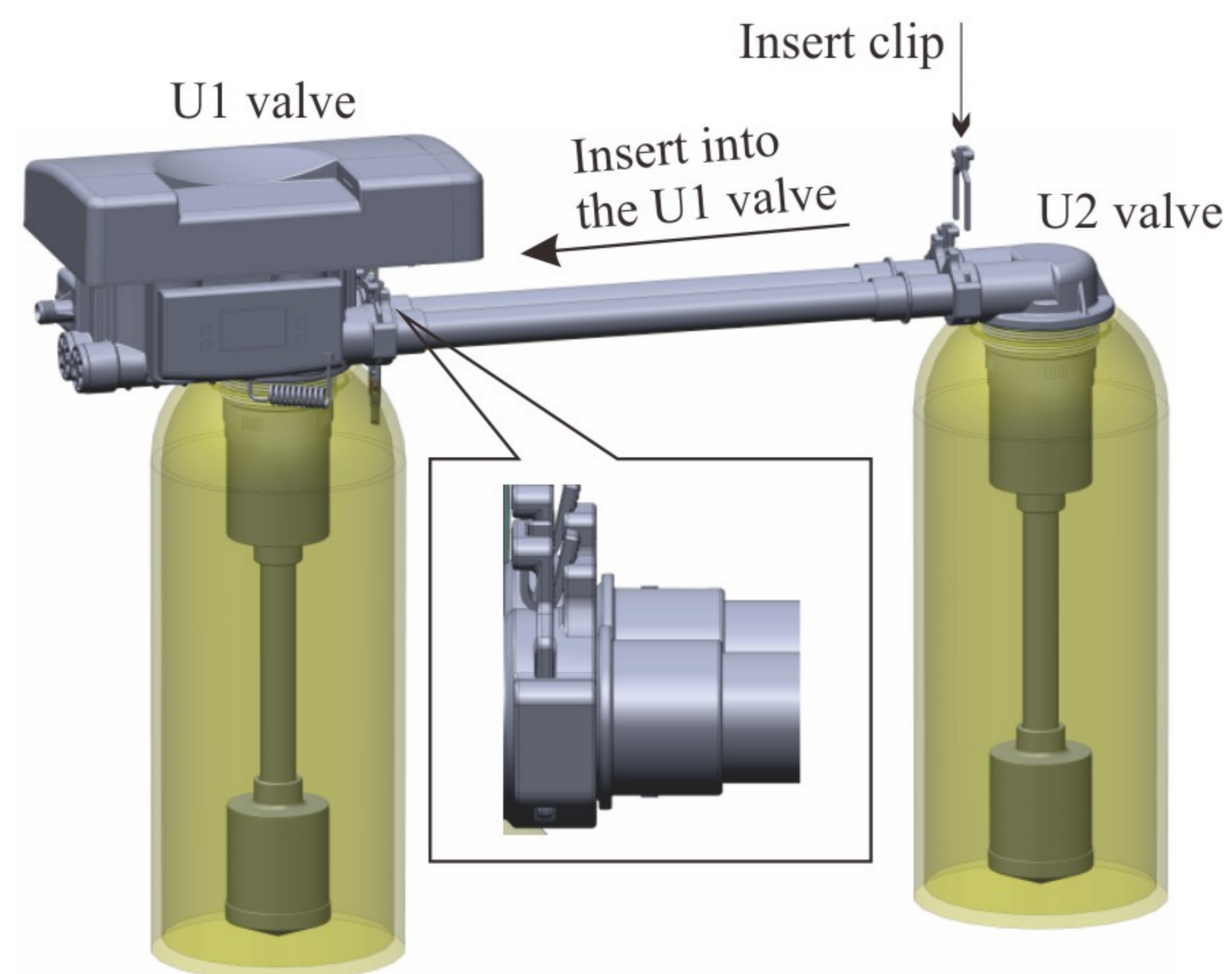

Figure2-2-4

D. Install flow meter and drain connector

As Figure 3 shows (take 17610T for example):

1. Install the flow meter and sealing ring on outlet.
2. Insert the probe wire into flow meter.
3. Put the animated nut, connector, sealing ring and DLFC (if have) on drain.

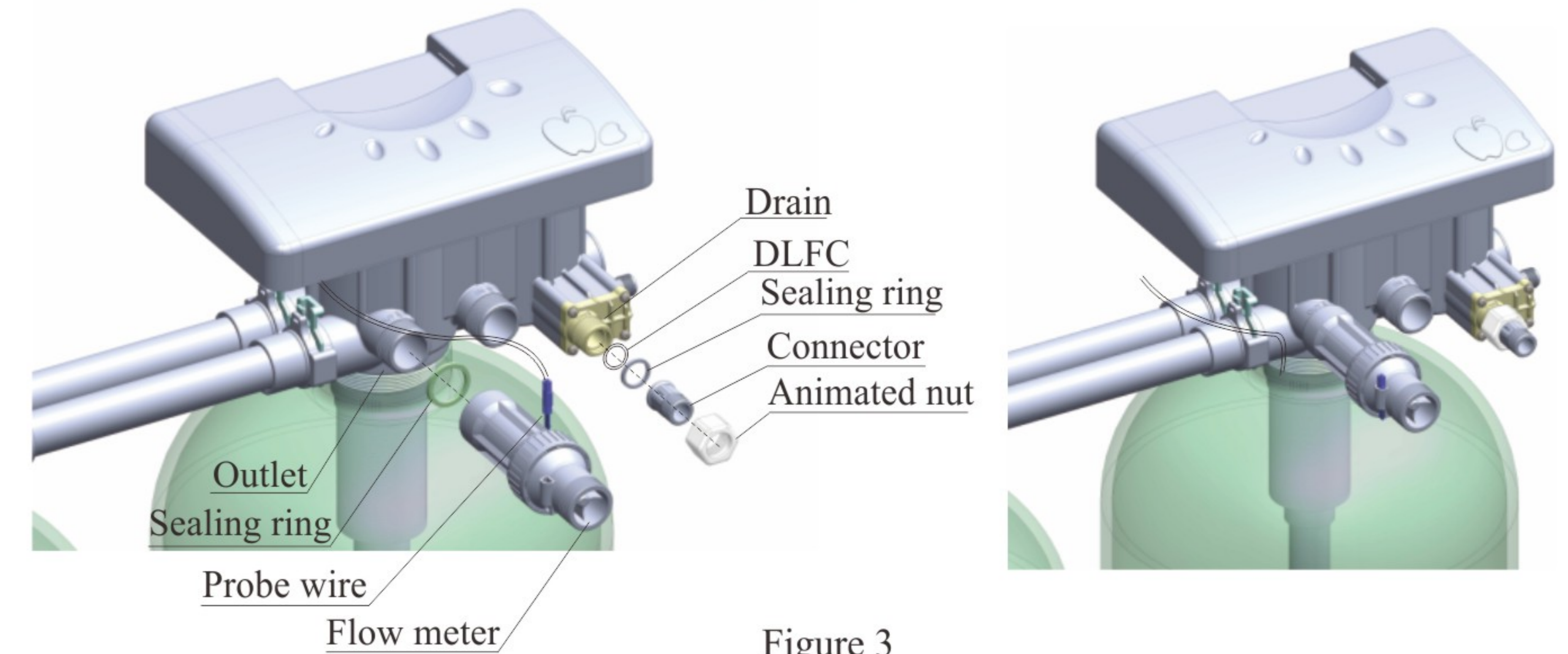

Figure 3

E. Pipeline connection

As Figure 4 shows (take 17610T for example):

1. Install pressure gauge and valve C on inlet, install valve A and sampling valve on outlet.
2. Install valve B on the middle of pipeline, and fix with support.
3. Use 3/4" UPVC pipe as drain pipeline and 1/2" (DN15)UPVC pipe as brine pipeline.
4. Brine pipeline use: ①1/2"(DN15) UPVC pipe (please use it first); ②Ø12 flexible tube.

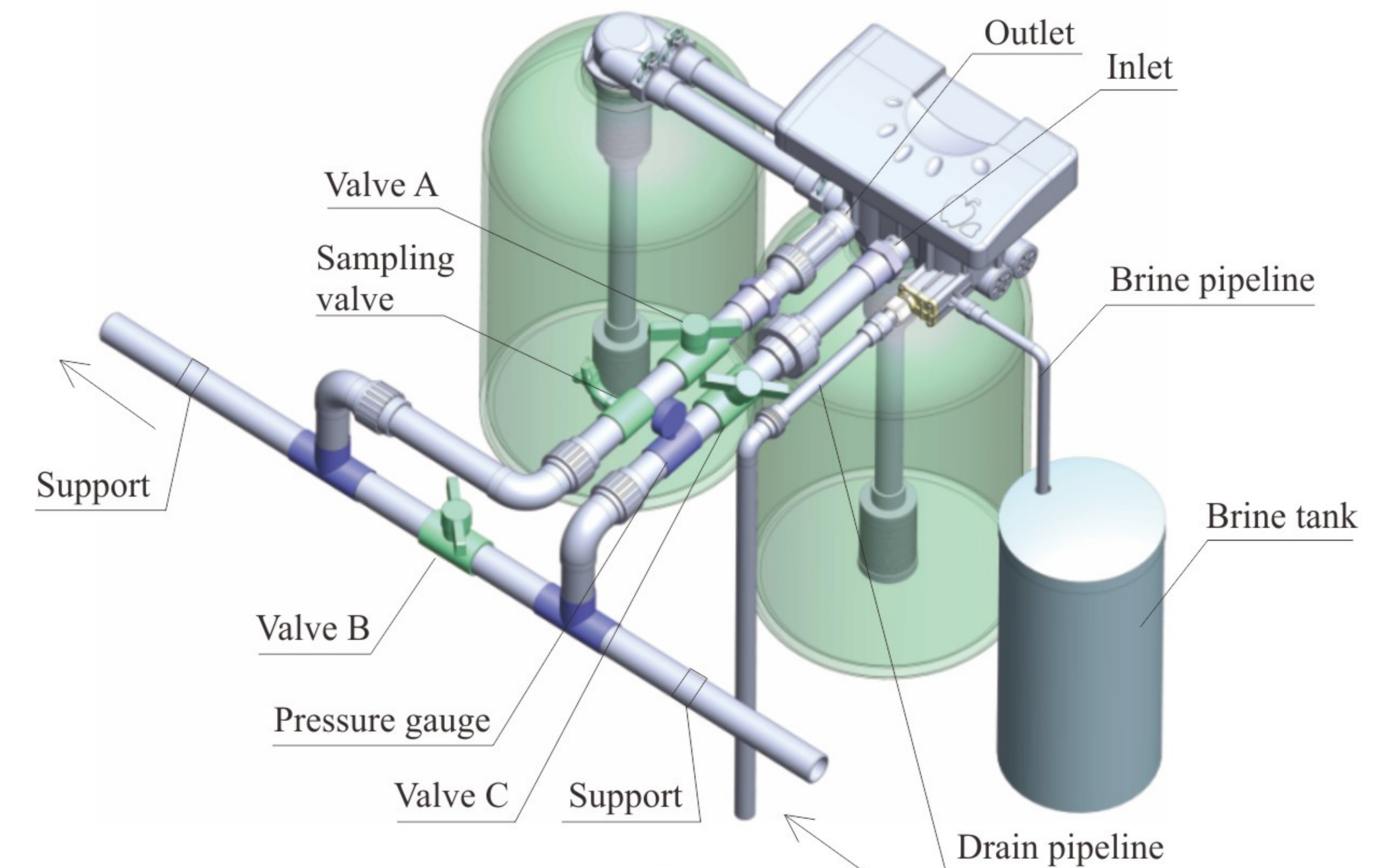

Figure 4

Notice:

- Control valve should be higher than drain outlet, and be better not far from the drain hose.
- Be sure not connect drain with sewer directly, and leave a certain space between them, to avoid wastewater being absorbed to the water treatment equipment.
- Brine pipeline should be as short and smooth as possible. There should be no more than four elbows on the brine pipeline to prevent poor salt absorption.
- There must be brine valve installed in brine tank.
- 17606T use Φ12 flexible tube as brine pipe.

2. Basic Setting & Usage

2.1. The Function of PC Board

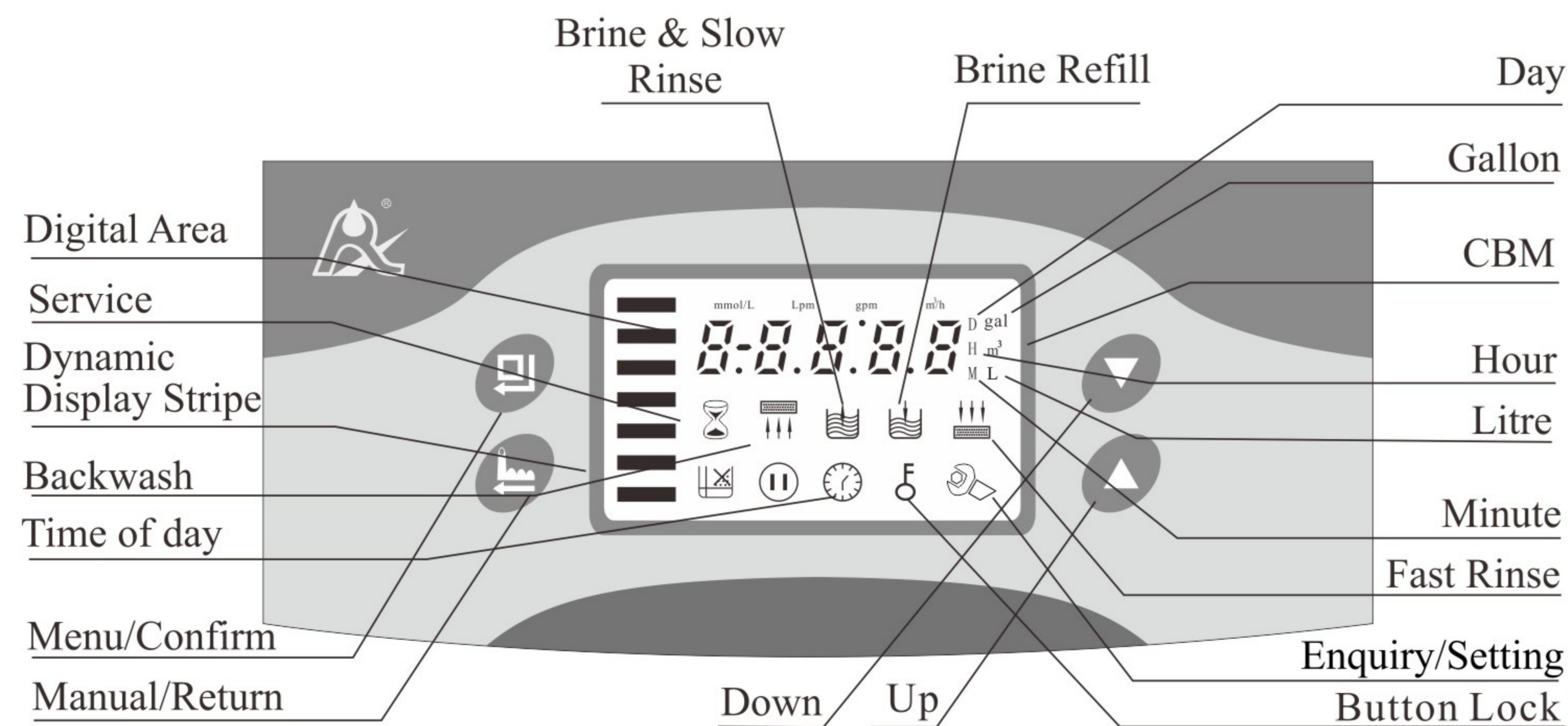

- A. Time of day indicator
- Lights on, display the time of day.
- B. Button lock indicator
- Lights on, indicating the buttons are locked. At this moment, press any single button will not work (No operation in one minute, will light on and lock the buttons.)
 - Solution: Press and hold both and for 5 seconds until the lights off.
- C. Program mode indicator
- Lights on, enter program display mode. Use or to view all values.
 - Flashes, enter program set mode. Press or to adjust values.
- D. Menu/Confirm button
- In menu mode, Press , lights on, enter program display mode view all values.

- In program display mode, press and flashes on, then enter program set mode, adjusting all values.
 - Press after all program are set, and then the voice “Di” means all setting are success and return program display mode.
- E. Manual/Return button
- Press in any status, it can proceed to next step. (For example: if the outlet water is unqualified, after unlock buttons, press in Service status, it will start regeneration cycles instantly; During regeneration cycles, if you want to terminate a step in advance, press to move on to the next step.)
 - Press in program display mode, and it will return in Service; Press in program set mode, and it will return program display mode.
 - Press while adjusting the value, then it will return program display mode directly without saving value.
- F. Down and Up
- In program display mode, press or to view all values.
 - In program set mode, press or to adjust values
 - Press and hold both and for 5 seconds to unlock the buttons.

2.2. Basic Setting & Usage

A. Parameter specification

Function	Indicator	Factory Default	Parameter Set Range	Instruction
Time of Day	12:12	Random	00:00~23:59	Set the time of day when use; “:” flashes.
Control Mode	A-01	A-01	A-01	Normal type: regeneration immediately when the available volume of treated water drops to zero (0).
			A-02	Intelligent type: regenerate starts when the available volume of treated water calculated according parameters drops to zero (0).
Water Treatment Capacity	80.00	80.00	0~999.99	Water treatment capacity in one circle (m ³).
Unit Mode	HU-01	HU-01	01, 02, 03	01-m ³ ; 02-gal; 03-L
Resin Volume	50L	50L	20~500	The resin volume in tank (L).

MODEL: F135/17610T-F137/17606T

Feed Water Hardness	Yd1.2	1.2	0.1~9.9	Hardness of feed water (mmol/L).
Exchange Factor	AL.65	0.65	0.30~0.99	Relate to the raw water hardness. When hardness is higher, the factor is smaller.
Fast Rinse		10:00	0~99:59	Fast rinse time (Minute)
Backwash		10:00	0~99:59	Backwash time (Minute)
Brine & Slow Rinse		70:00	0~99:59	Brine & Slow rinse time (Minute)
Brine Refill		05:00	0~99:59	Brine refill time (Minute)
Maximum Interval Regeneration Days	H-30	30	0~40	Regenerate on the day even though the available volume of treated water does not drop to zero (0).
Output Control Mode	b-01	01	01 or 02	b-01: Signal will turn on during the regeneration. b-02: Signal is only available at intervals of regeneration cycles and in service. (Refer to P4).

B. Process Display

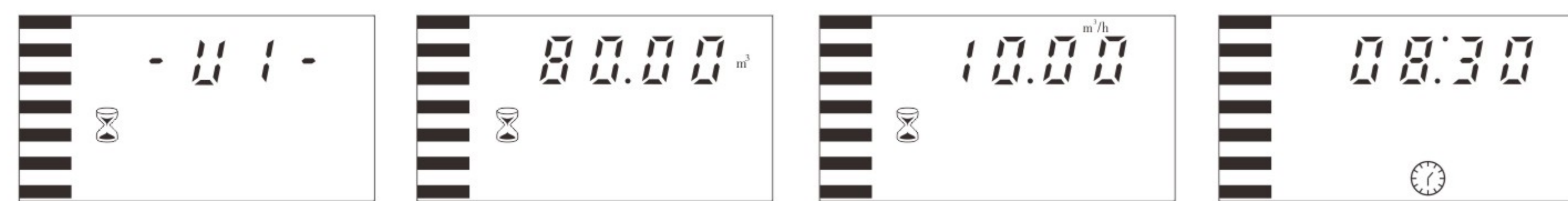

Figure 1A Figure 1B Figure 1C Figure 1D

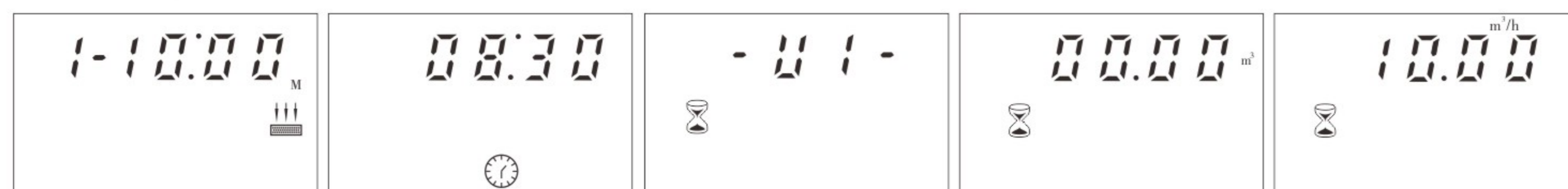

Figure 2A Figure 2B Figure 2C Figure 2D Figure 2E

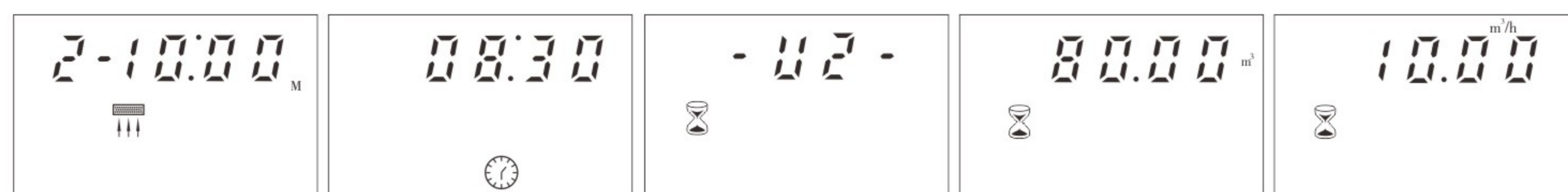

Figure 3A Figure 3B Figure 3C Figure 3D Figure 3E

MODEL: F135/17610T-F137/17606T



Figure 4A Figure 4B Figure 4C Figure 4D Figure 4E

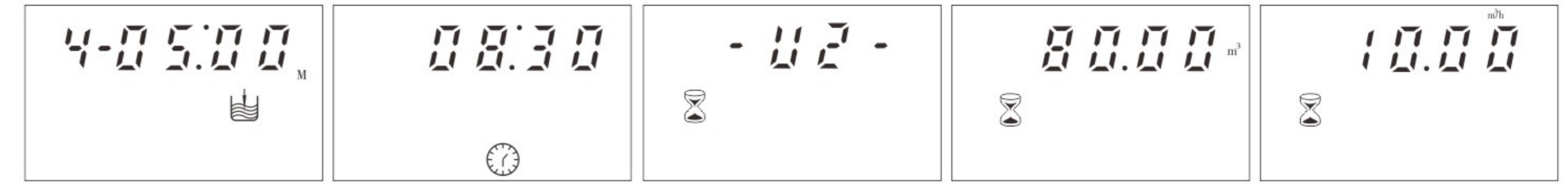

Figure 5A Figure 5B Figure 5C Figure 5D Figure 5E

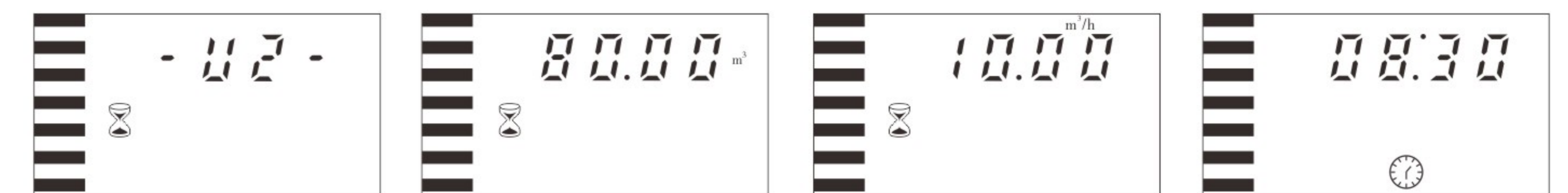

Figure 6A Figure 6B Figure 6C Figure 6D



Figure 7A Figure 7B Figure 7C Figure 7D Figure 7E



Figure 8A Figure 8B Figure 8C Figure 8D Figure 8E



Figure 9A Figure 9B Figure 9C Figure 9D Figure 9E

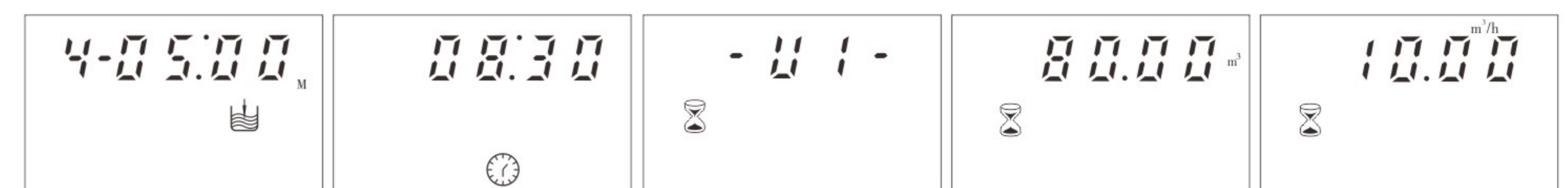

Figure 10A Figure 10B Figure 10C Figure 10D Figure 10E

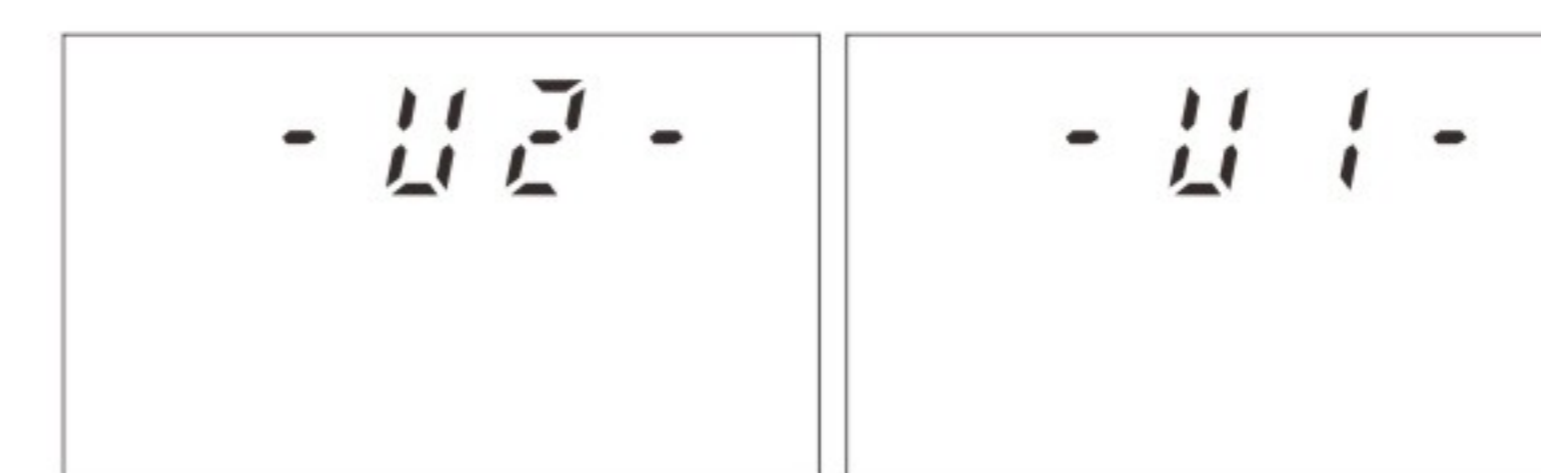

Figure 11A Figure 11B

Notice:

- When tank U1 in Service while tank U2 is standby: Figure 1A/1B/1C/1D display every 5 seconds in cycle.
- When tank U1 in Service while tank U2 in Fast Rinse: Figure 2A/2B/2C/2D/2E display every 5 seconds in cycle.
- Service tank switching from U1 tank to U2 tank display as Figure 11A; Service tank switching from U2 tank to U1 tank display as Figure 11B.
- When tank U2 in Service while tank U1 in Backwash: Figure 3A/3B/3C/3D/3E display every 5 seconds in cycle.
- When tank U2 in service while tank U1 in Brine & Slow Rinse: Figure 4A/4B/4C/4D/4E display every 5 seconds in cycle.
- When U2 in Service while tank U1 in Brine Refill: Figure 5A/5B/5C/5D/5E display every 5 seconds in cycle.
- When tank U2 in Service while tank U1 is standby: Figure 6A/6B/6C/6D/6E display every 5 seconds in cycle.
- When tank U2 in Service while tank U1 in Fast Rinse: Figure 7A/7B/7C/7D/7E display every 5 seconds in cycle.
- When tank U1 in Service while tank U2 in Backwash: Figure 8A/8B/8C/8D/8E display every 5 seconds in cycle.
- When tank U1 in service while tank U2 in Brine & Slow Rinse: Figure 9A/9B/9C/9D/9E display every 5 seconds in cycle.
- When U1 in Service while tank U2 in Brine Refill: Figure 10A/10B/10C/10D/10E display every 5 seconds in cycle.
- Display screen shows “-00-”or“F-00”when motor is switching.
- The time of day figure “🕒” flashes continuously, such as “12:12” flashes, indicates long outage of power. It reminds to reset the time of day.
- The display will show the error code, such as “-E11-” when the system is in error.













C. Usage

After being accomplished installation, parameter setting and trial running by professional, the valve could be put into use. In order to ensure the quality of outlet water can reach the requirement, the user should complete the below works:

- ①Ensure that there is solid salt all the time in the brine tank in the course of using when this valve is used for softening. The brine tank should be added the crystalline coarse salt only, at least 99.5% pure, forbidding use the small salt and iodized salt.
- ②Test the outlet water and raw water hardness at regular time. When the outlet water

hardness is unqualified, please press the  after unlock the buttons and the valve will temporarily regenerate again (It will not affect the original set operation cycle).

③When the feed water hardness changes a lot, you can adjust the water treatment capacity as follow:

Press and hold both  and  for 5 seconds to unlock the lock status. Press , and the  lights on, then press , the digital area show the control mode (Such as show A-01), then press  and the digital area will show the given water treatment capacity; Press  again,  and digital number flash, enter water treatment capacity set mode. Press  or  continuously, reset the capacity value (Or water hardness). Press  and hear a sound “Di”, then finish the adjustment. Press  exit and turn back the service status.

The estimates of cycle water treatment capacity value can refer to the professional application instruction. When select A-02 as the control mode, controller will calculate the cycle water treatment capacity automatically by setting feed water hardness, resin volume and exchange factor.

The regeneration parameters have been set when control valve left factory. Generally, it does not need to reset. If you want enquiry and modify the setting, you can refer to the professional application specification.

3. Applications

3.1 Softener Flow Chart

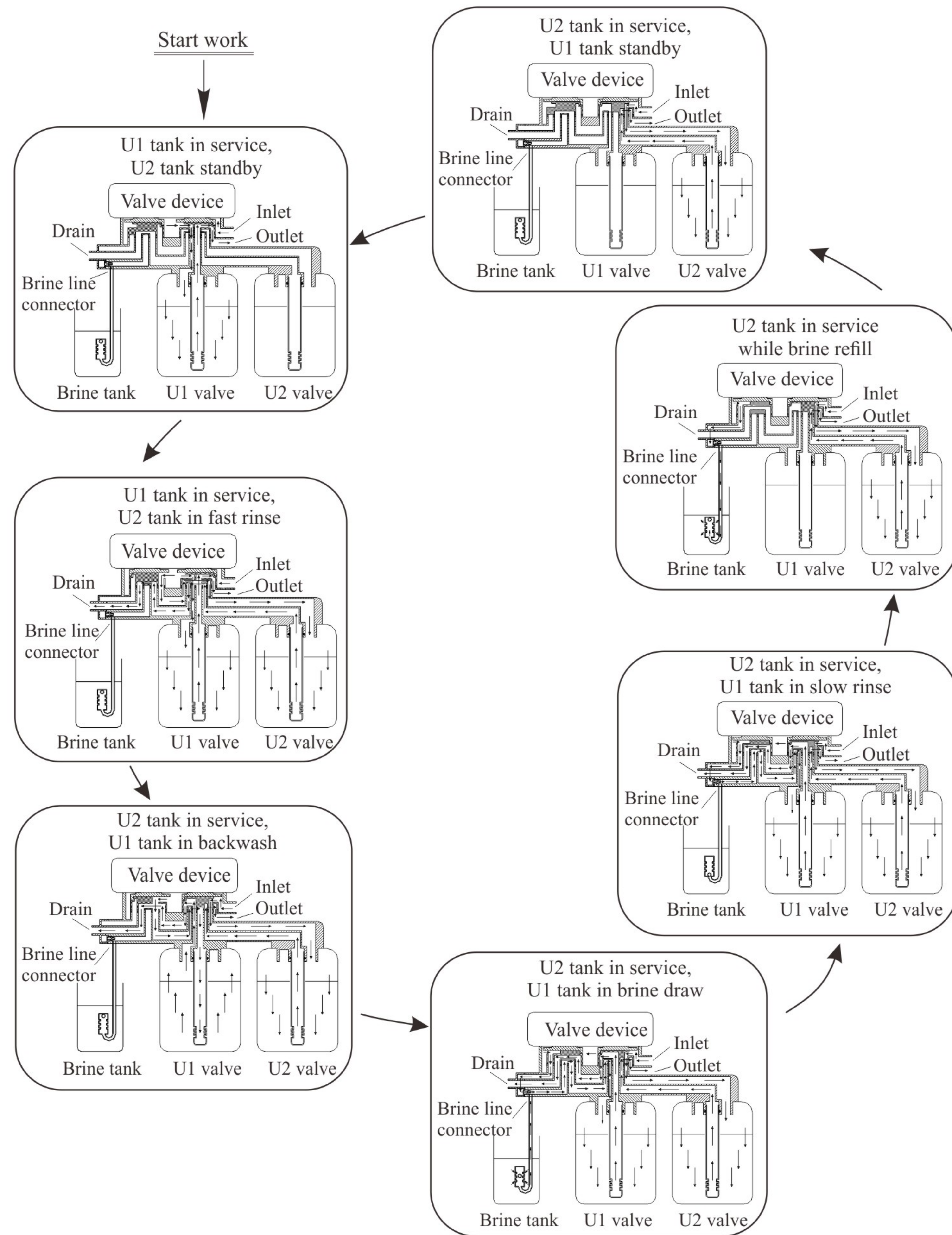

3.2 The Function and Connection of PC Board

Open the front cover of control valve, you will see the main control board and connection port as Figure 3-1:

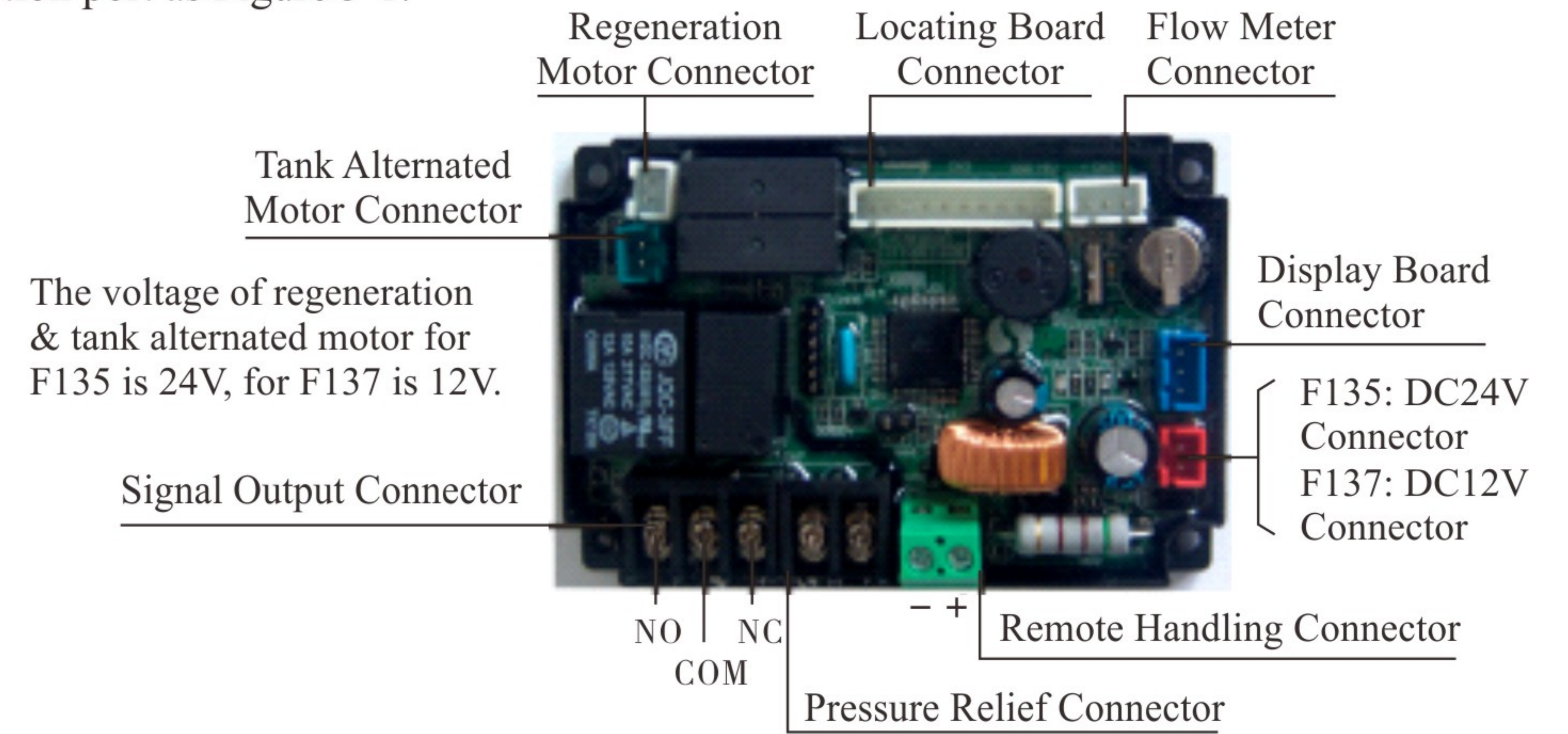

Figure 3-1

The main functions on main control board:

Function	Application	Explanation
Signal output connector b-01	Outlet solenoid valve	Used in strict requirements regarding no hard water flowing from outlet or controlling the liquid level in water tank.
	Inlet pump	Increase pressure for regeneration or washing. Use the liquid level controller to control inlet pump to ensure there is water in tank.
Signal output connector b-02	Inlet solenoid valve or inlet pump	When inlet pressure is high, it needs to close water inlet to protect motor when valve is rotating.
Pressure relief connector	Control pump water supply	When valve is rotating, pressure relief connector is opened to prevent pressure increasing rapidly.
Remote handling connector	Receive signal to make the control valve rotate to next circle	It is used for online inspection system, connected with PC to realize automatically or remotely controlling valve.

A. Signal Output Connector

1) Control Outlet Solenoid Valve (Set b-01)

① Solenoid Valve on Outlet Controls Water Level in Water Tank.

Instruction: If system strictly requires no hard water flowing from outlet in regeneration cycle (Mainly for no hard water flows out when valve is switching or valve in backwash or brine drawing positions), a solenoid valve could be installed on outlet, the wiring refers to Figure 3-2.

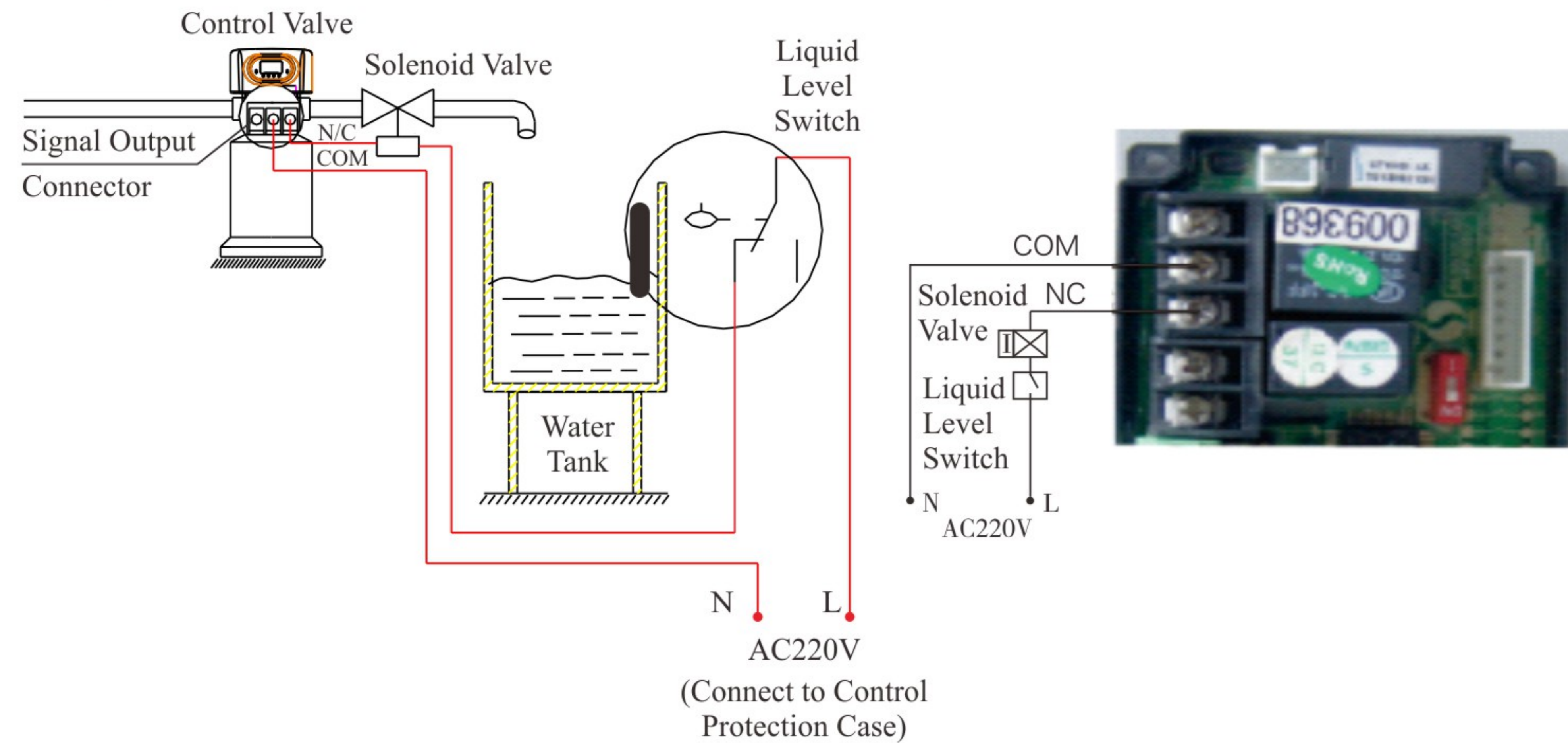

Figure 3-2 Wiring of Outlet Solenoid Valve

Function:

When valve is in service status, if soft water tank is short of water, solenoid valve will open to supply soft water, but if water tank has enough water, solenoid valve will close, so no soft water is supplied to the tank.

When the valve is in backwash status, there is no signal output. So, solenoid valve is closed, and no raw water flows into soft water tank.

② Control Inlet Solenoid Valve (Set b-02)

Instruction: When inlet pressure exceeds 0.6MPa, install a solenoid valve on inlet. Control mode is b-02. Pressure is relieved when valve switching, the wiring refers to Figure 3-3. As Figure 3-4 shows, it also can use the pressure relief port to work.

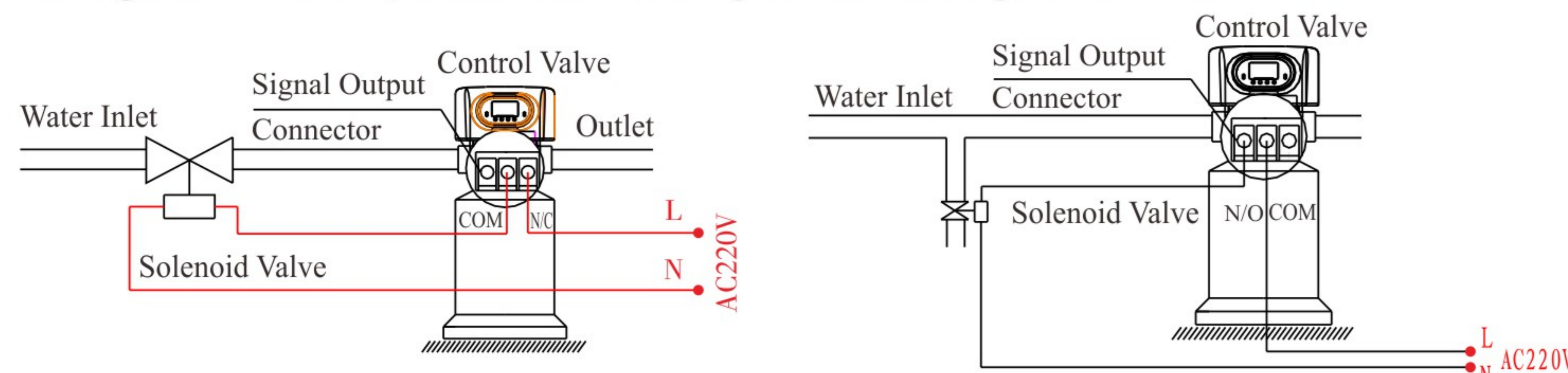

Figure 3-3 Wiring of Solenoid Valve on Inlet

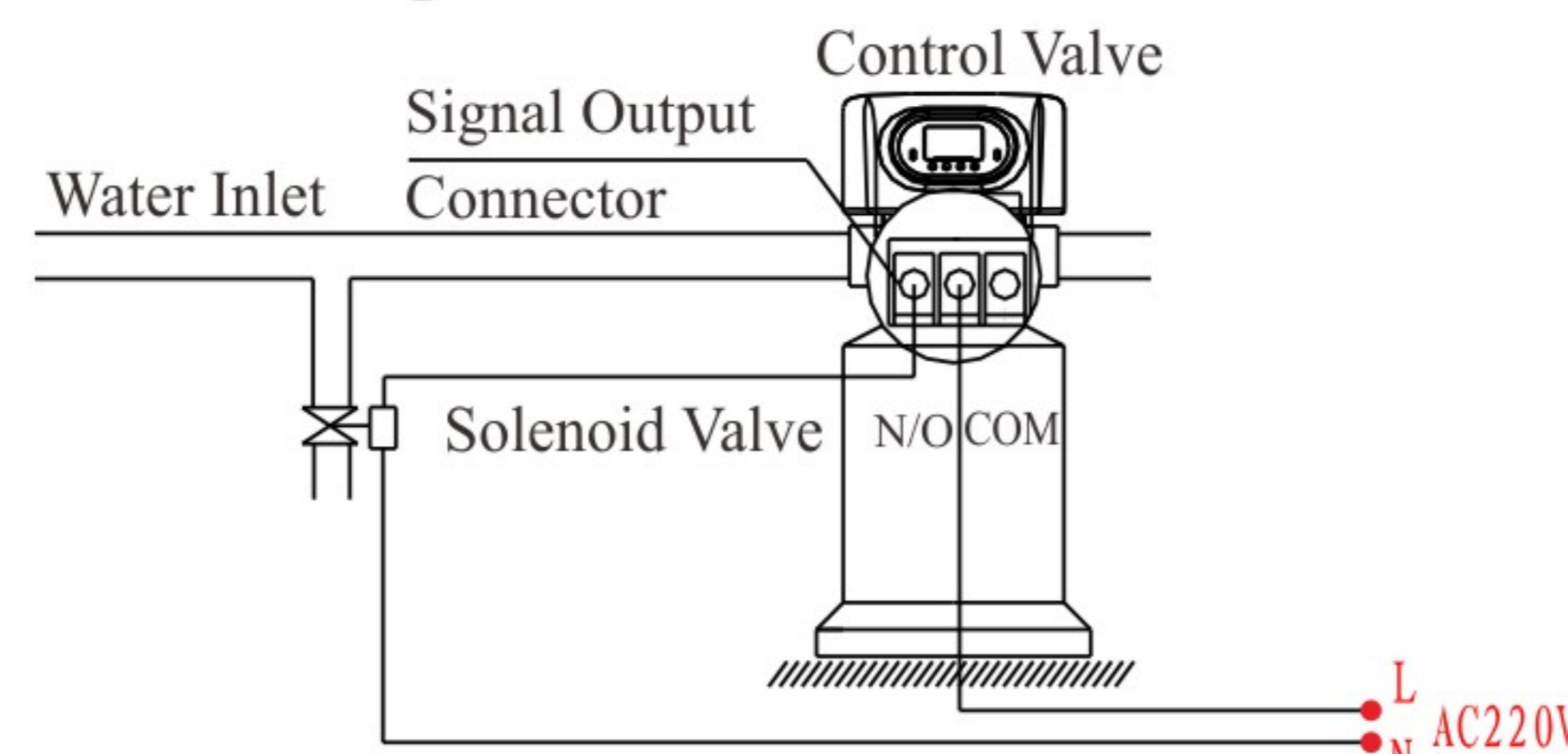

Figure 3-4 Wiring of Pressure Relief Connector

Function:

When inlet pressure is high, install a solenoid valve on inlet to ensure valve switches properly. The solenoid valve will open when valve is exactly at position of U1 tank in service while U2 tank standby, U1 tank in service while U2 tank in fast rinse, U2 tank in service while U1 tank in backwash status. When valve is switching, solenoid valve is closed, no water flows into valve to ensure valve switching properly.

2) Liquid Level Controller Controls Inlet Pump (Two-phase motor) (Set b-01)

Instruction: For the system using underground water or middle-tank supplying water, users can turn on and turn off the pump by operating the switch of liquid level controller and control valve. The wiring refers to Figure 3-5:

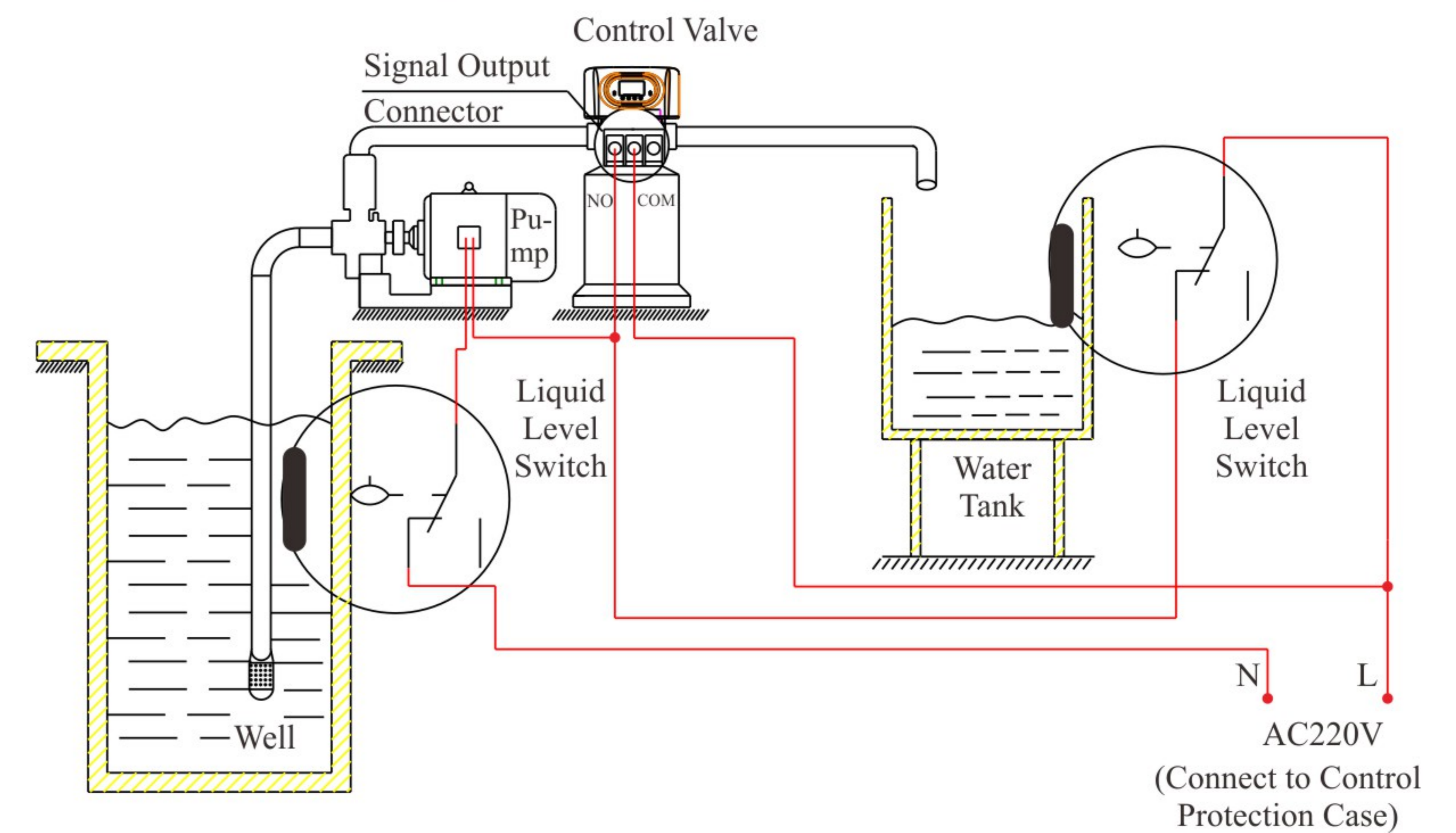

Figure 3-5 Wiring of Liquid Level Controller Controlling Inlet Pump

Function:

When valve is in standby status, if water tank is short of water, pump starts working, but if water tank has enough water, the switch of liquid level controller is closed, so pump doesn't work.

When valve in regeneration cycle, inlet always has water no matter what water condition in water tank is. As Runxin valve no water pass outlet in regeneration cycle, it ensure no lots of water fill into water tank.

A liquid switch at the top opening of well or in middle water tank in RO system protect pump from working without water in case of out of raw water.

3) Liquid Level Switch in Water Tank Controls Inlet Pump (Three-phase motor) (Set b-01)

This application applies the same principle as two-phase motor, only the single-phase pump is replaced by a three-phase motor with an AC contactor (Figure 3-6).

MODEL: F135/17610T-F137/17606T

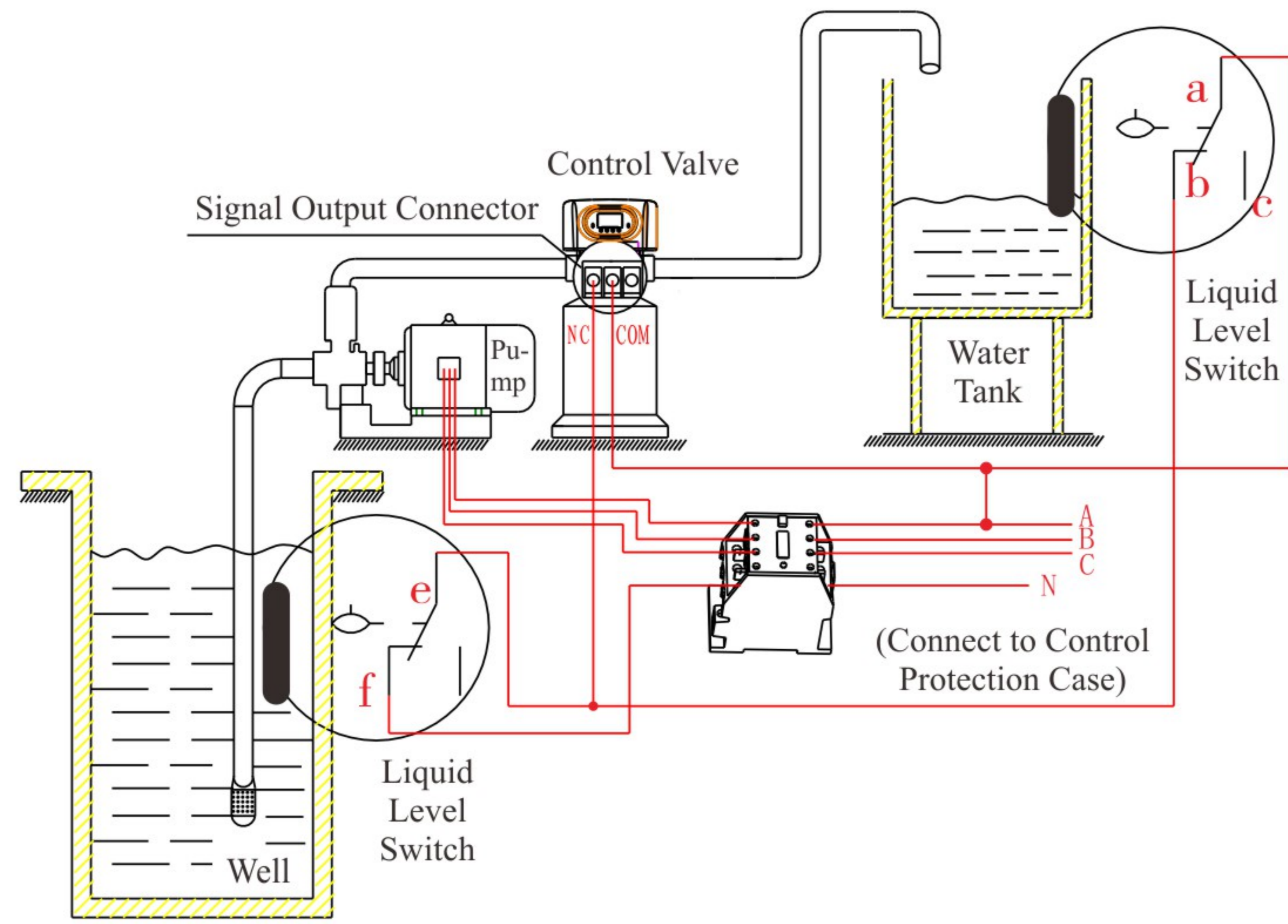

Figure 3-6 Wiring of Liquid Level Switch in Water Tank Controls 380V Inlet Pump

B. Pressure Relief Connector

Runxin valve will cut off feeding water to drain line when it switches in regeneration cycles. Thus in some water treatment system, e.g. Deep Well, one booster pump was installed on the inlet to increase the system water feeding pressure, this cut-off will cause pressure on inlet rising too fast to damage the valve. Pressure Relief Output can be used to avoid this problem. The wiring refers to Figure 3-7.

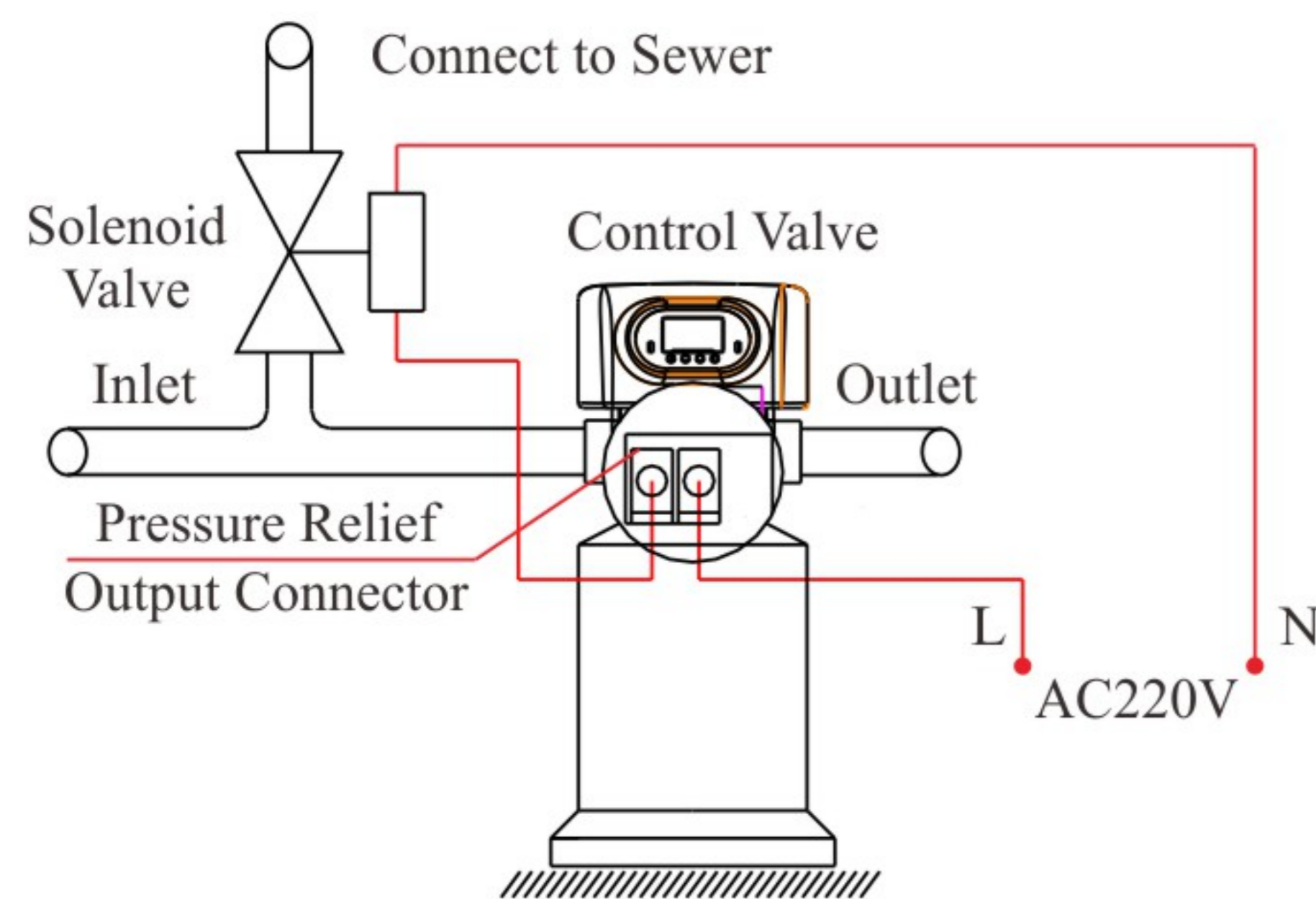

Figure 3-7 Wiring of Pressure Relief Connector

C. Remote Handling Connector

When the valve is used to make pure water or other system that can be monitored online or connected to a PC, etc., when the conductivity or other parameters reach the set value or the PC sends a signal and needs system regeneration, it can be provide a signal to remote

MODEL: F135/17610T-F137/17606T

handling connector of main control board by the signal line, which can make the valve regenerate immediately. The connector receiving the signal is equivalent to pressing the manual button. The wiring refers to Figure 3-8.

3.3 System Configuration and Flow Rate Curve

A. Product Configuration

Product configuration with tank, resin volume, brine tank and injector.

17610T:

Tank Size (mm)	Resin Volume (L)	Flow Rate (t/h)	Brine Tank Size (mm)	The Minimum Salt Consumption for Regeneration (Kg)	Injector Model
φ 400 × 1670	120	3.5	φ 550 × 1160	18.00	1#
φ 450 × 1670	150	4.5	φ 550 × 1160	22.50	
φ 500 × 1800	200	5.0	φ 740 × 1275	30.00	2#
φ 600 × 1800	300	7.0	φ 740 × 1275	45.00	3#
φ 750 × 1800	450	11.0	φ 840 × 1335	67.50	4#

17606T:

Tank Size (mm)	Resin Volume (L)	Flow Rate (t/h)	Brine Tank Size (mm)	The Minimum Salt Consumption for Regeneration (Kg)	Injector Model
φ 400 × 1670	120	3.5	φ 550 × 1160	18.00	2#
φ 450 × 1670	150	4.5	φ 550 × 1160	22.50	
φ 500 × 1800	200	5.0	φ 740 × 1275	30.00	3#
φ 600 × 1800	300	6.0	φ 740 × 1275	45.00	

Attention: The flow rate calculation is based on linear velocity 25m/h; the minimum salt consumption for regeneration calculation is based on salt consumption 150g / L (Resin).

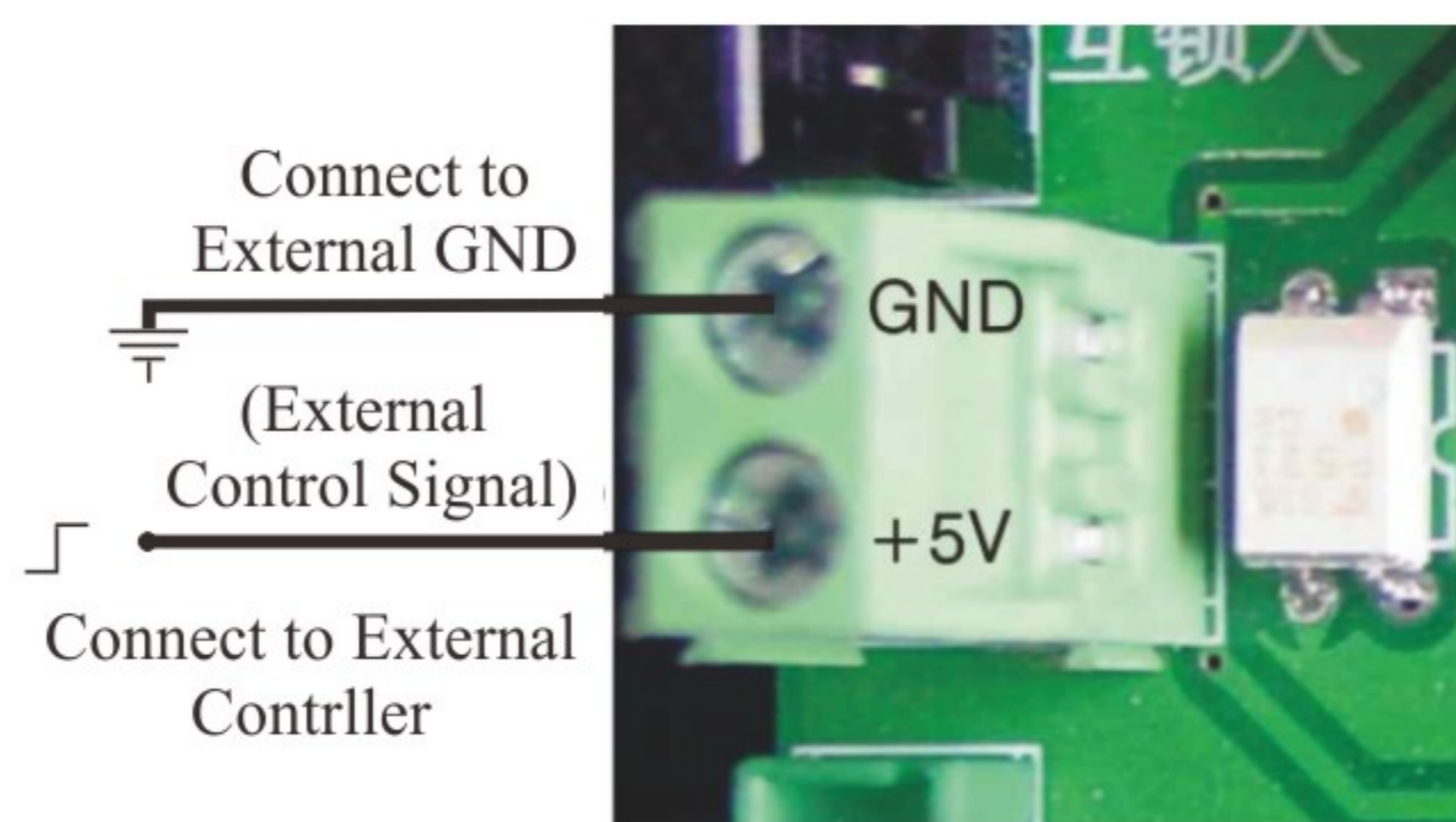

Figure 3-8 Wiring of Remote Handling Connector

MODEL: F135/17610T-F137/17606T

B. Flow Rate Characteristic

1). Pressure flow rate curve

17610T:

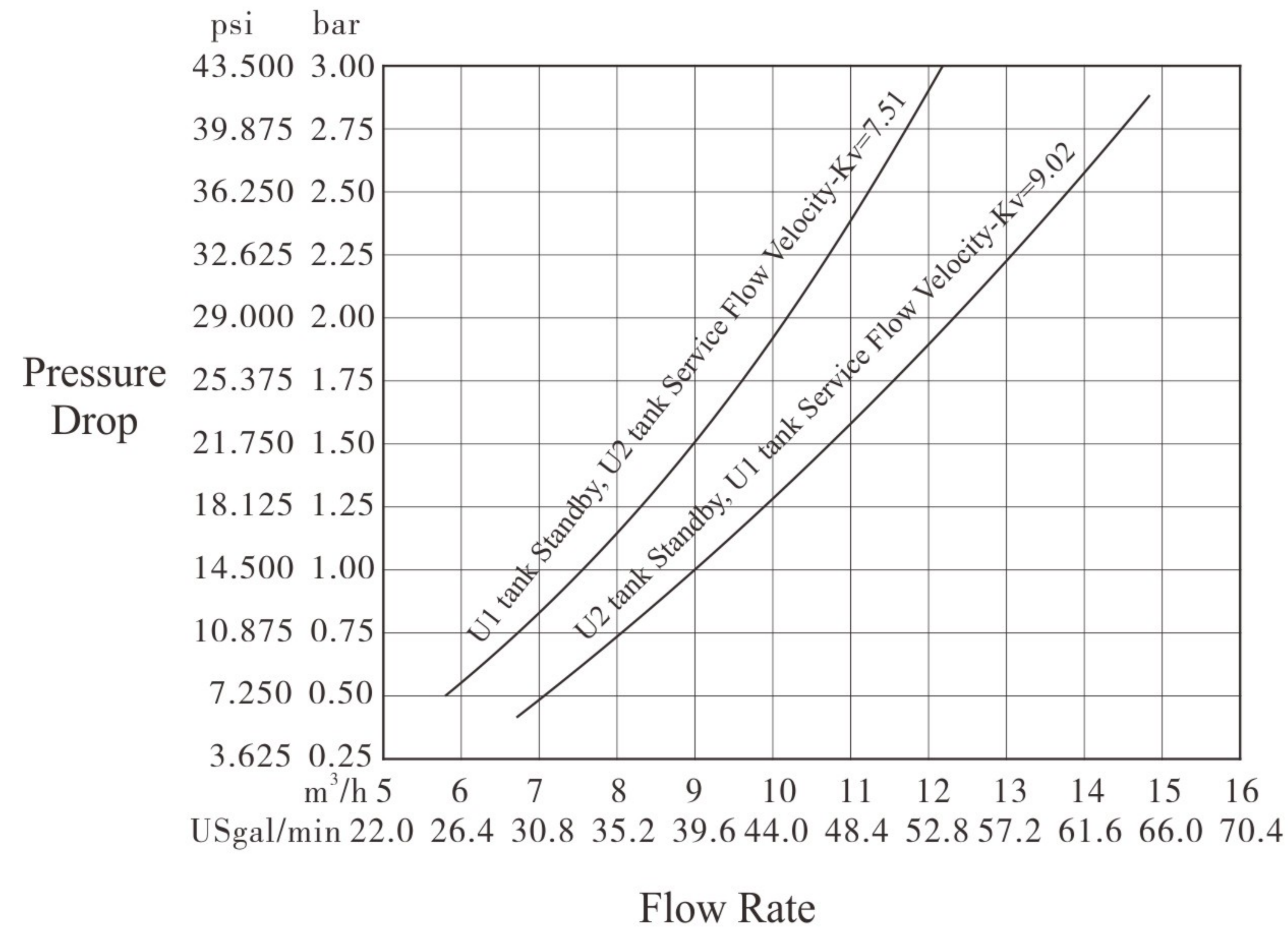

17606T:

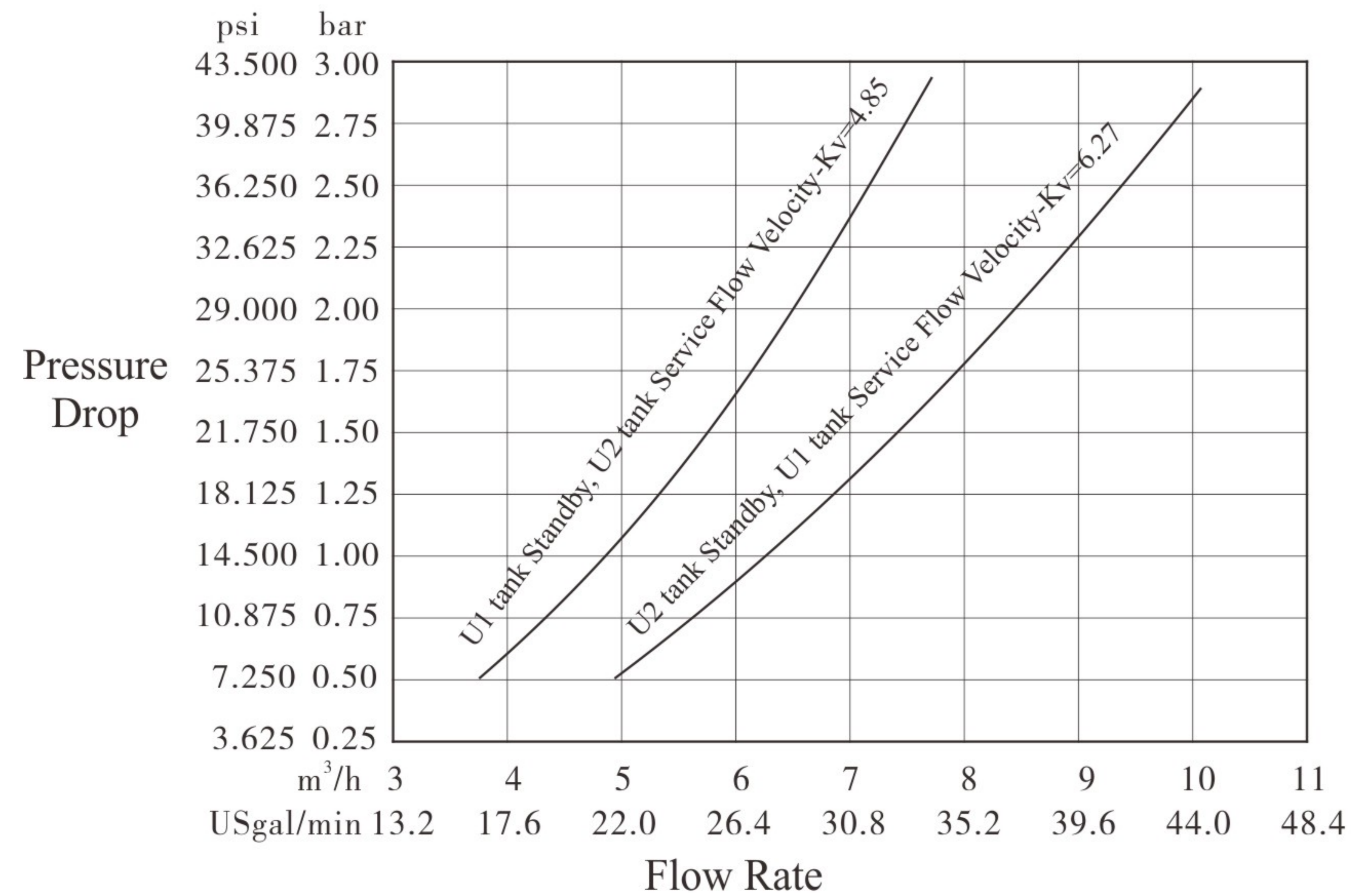

MODEL: F135/17610T-F137/17606T

2). Injector parameter table

17610T:

Inlet Pressure	Draw Rate (L/M)			
	1#	2#	3#	4#
MPa				
0.15	6.90	11.20	17.55	25.20
0.20	8.05	13.05	19.90	29.45
0.25	9.35	14.70	22.35	32.85
0.30	10.50	16.35	24.75	36.05
0.35	11.55	17.60	26.90	39.85
0.40	12.25	18.55	28.35	42.05

17606T:

Inlet Pressure	Draw Rate (L/M)		
	2# injector (8468238 DLFC)	2# injector (8468008 DLFC)	3# injector
MPa			
0.15	9.15	10.05	16.55
0.20	10.45	11.45	19.05
0.25	11.60	12.80	21.35
0.30	12.80	14.10	23.40
0.35	13.75	15.15	25.35
0.40	14.80	16.30	26.80

3). Configuration for Standard Injector and Drain Line Flow Control

17610T:

Tank Dia. mm	Injector Model	Injector Color	Draw Rate	Slow Rinse	Brine Refill	DLFC	Backwash / Fast Rinse
			L/m	L/m	L/m		L/m
400	1#	Coffee	10.50	6.64	17.78	8468238	39.50
450							

MODEL: F135/17610T–F137/17606T

500	2#	Pink	16.35	9.85	28.40	8468008	58.33
535							
600	3#	Yellow	24.75	18.29	44.74	8468009	72.50
750	4#	Blue	36.05	27.45	57.20	Without DLFC	80.33

17606T:

Tank Dia. mm	Injector Model	Injector Color	Draw Rate	Slow Rinse	Brine Refill	DLFC	Backwash / Fast Rinse
			L/m	L/m	L/m		L/m
400	2#	Pink	12.80	9.15	16.85	8468238	36.00
450							
500	2#	Pink	14.10	9.17	16.85	8468008	51.83
535							
600	3#	Yellow	23.40	17.42	18.35	Without DLFC	63.00

Remark:

- The experimental data in the table above are all tested under the inlet pressure of raw water at 0.3MPa.
- Above data for the product configuration and relevant characteristics are only for reference. When put in practice, please subject to the different requirements of raw water hardness and application.

3.4 Parameter settlement

①Service Time T1

Water Treatment Capacity: $Q = V_R \times K \div Y_D$ (m³)

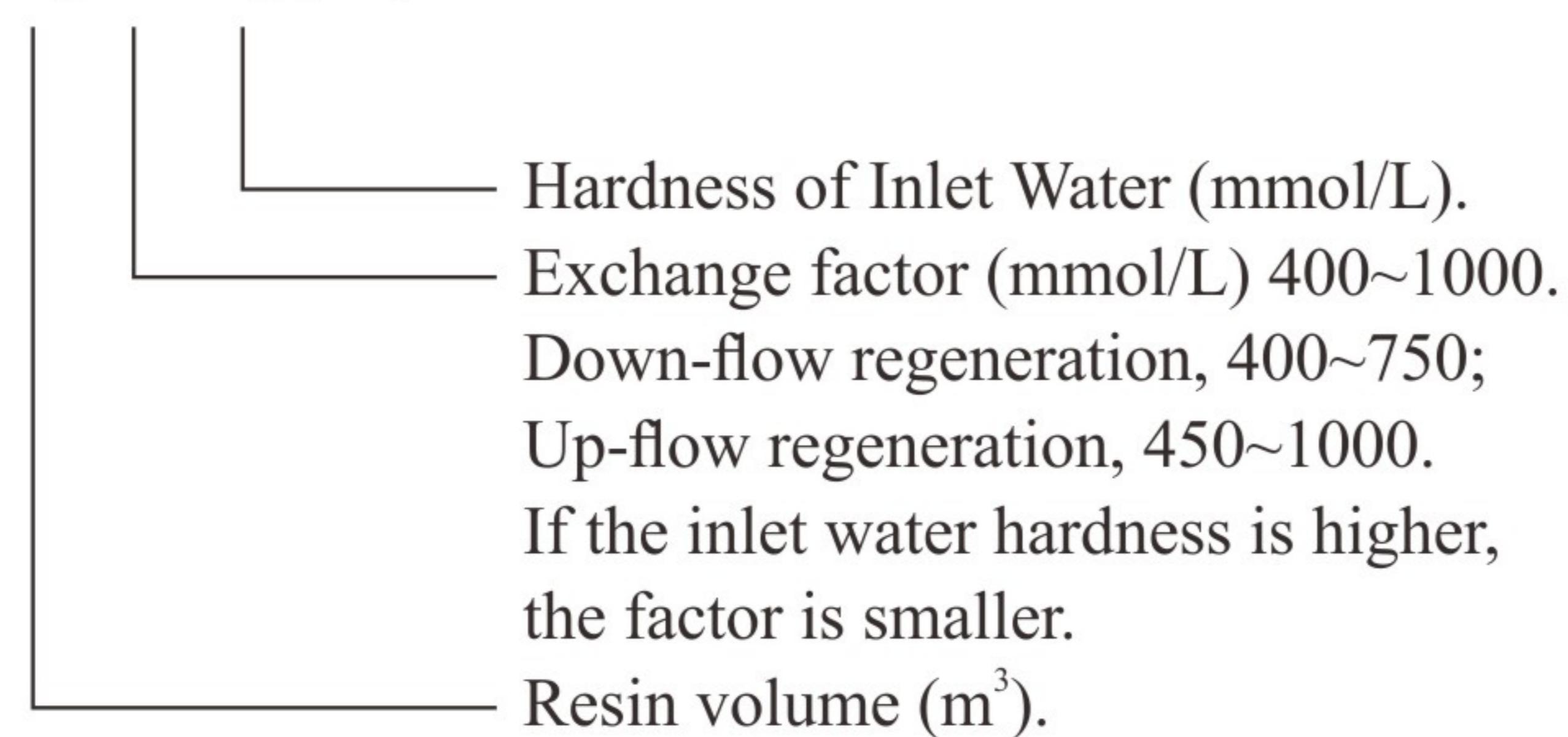

MODEL: F135/17610T–F137/17606T

By hours: $T1 = Q \div Q_h$ (Hour)

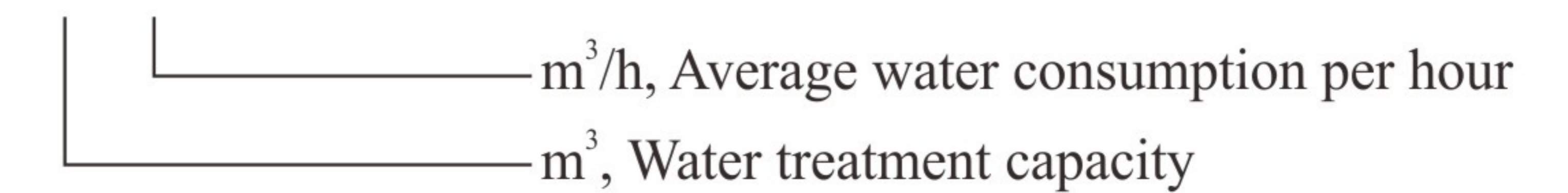

By days: $T1 = Q \div Q_d$ (day)

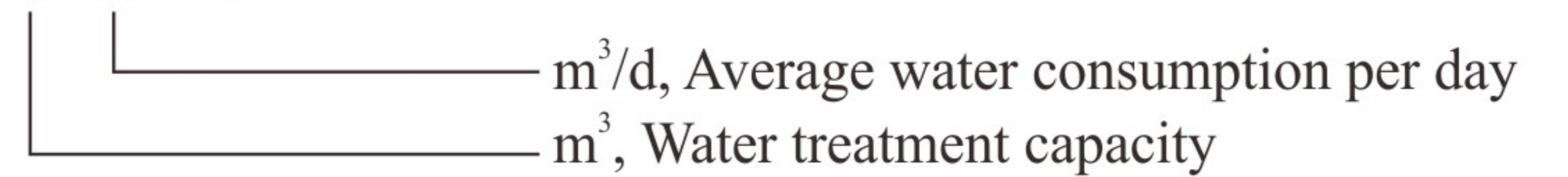

② Backwash time T2

It is subject to the turbidity of inlet water. Generally, it is suggested to be set 10~15 minutes. The higher the turbidity is, the longer backwash time can be set. However, if the turbidity is more than 5FTU, it should be better to install a filter in front of the exchanger.

③ Brine & slow rinse time T3

$T3 = (40 \sim 50) \times H_R$ (min.)

Generally, $T3 = 45 H_R$ (min.)

In this formula, H_R —The height of resin in exchange tank (m).

④ Brine refill time T4

Down-flow regeneration: $T4 = 0.45 \times V_R \div \text{Brine refill speed}$

Up-flow regeneration: $T4 = 0.34 \times V_R \div \text{Brine refill speed}$

In this formula, V_R —Resin volume (m³).

The Brine refill speed is related to inlet water pressure. It is suggested to lengthen 1~2 minutes of calculated brine refilling time to make sure there is enough water in tank. (The condition is that there is a brine valve installed in the brine tank)

⑤ Fast rinse time T5

$T5 = 12 \times H_R$ (min.)

Generally, the water for fast rinse is 3~6 times of resin volume. It is suggested to be set 10~16 minutes, but subject to the outlet water reaching the requirement.

⑥ Exchange factor

Exchange factor = $E / (k \times 1000)$

In this formula, E —Resin working exchange capability (mol/m³), it is related to the quality of resin. Down-flow regeneration, take 800~900. Up-flow regeneration, take 900~1200.

K —Security factor, always take 1.2~2, it is related to the hardness of inlet water: the higher the hardness is, the bigger the K is.

The calculation of parameters for each step is only for reference, the actual proper time will be determined after adjusting by water exchanger supplier. This calculation procedure of softener is only for industrial application; it is not suitable for small softener in residential application.

3.5 Parameter Enquiry and Setting

(1) Parameter Enquiry

When lights on, press and hold both and for 5 seconds to unlock buttons; then press and lights on, enter into program display mode; press or to view each value according to below process. (Press exit and turn back to service status.)

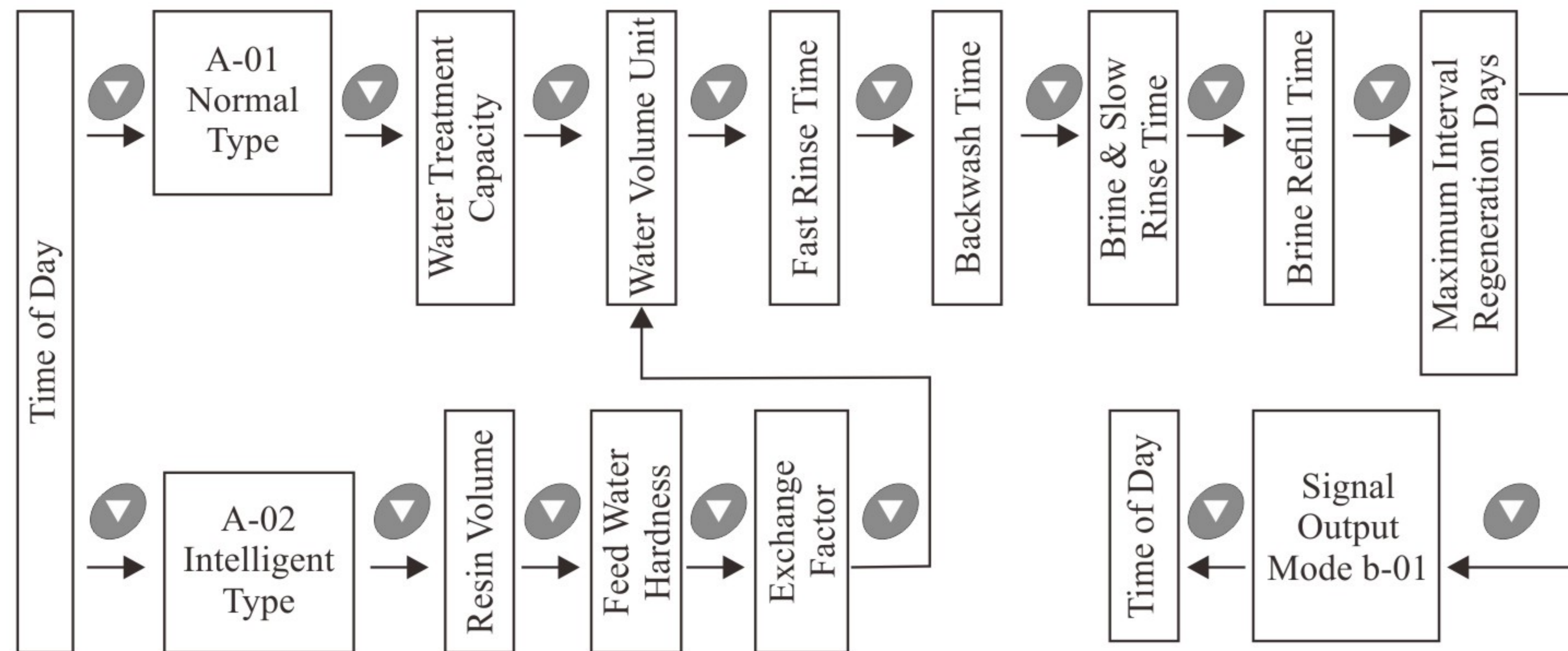



















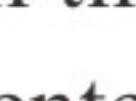

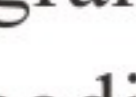







(2) Parameter Setting

In program display mode, press , enter program set mode. Press or to adjust the value.













(3) The steps of parameter setting

Item	Process Step	Symbol
Time of Day	<p>When time of day "12:12" continuously flashes, it reminds to reset.</p> <ol style="list-style-type: none"> 1. Press to enter program display mode; both and symbols light on, ":" flashes. 2. Press to enter program set mode, both and hour value flash, through or to adjust hour value. 3. Press again, both and minute value flash, through or to adjust the minute value. 4. Press button to finish adjustment then press to return. 	
Control Mode	<ol style="list-style-type: none"> 1. Press in control mode enquiry status to enter into setting status, then and 01 flash. 2. Press or , set the value to be A-01, or A-02 control mode. 3. Press button to finish adjustment then press to turn back. 	

Water Treatment Capacity	<ol style="list-style-type: none"> 1. In water treatment capacity display status, it shows and 80.00. Press and enter program set mode. and 80 flash. Press or to adjust the integer place of water treatment capacity. 2. Press again and enter program set mode. and 00 flash, press or to adjust the decimal place of water treatment capacity. 3. Press and to finish adjustment then press to return. 	
Resin Volume	<ol style="list-style-type: none"> 1. In resin volume display status, it shows 50L. Press and enter program set mode. and 50 value flash. 2. Press or to adjust the volume value (L). 3. Press to finish adjustment then press to return. 	
Feed Water Hardness	<ol style="list-style-type: none"> 1. In feed water hardness display status, it shows yd1.2. Press and enter program set mode. and 1.2 value flash. 2. Press or to adjust the hardness value (mmol/L). 3. Press to finish adjustment then press to return. 	
Exchange Factor	<ol style="list-style-type: none"> 1. In exchange factor display status, it shows AL0.55. Press and enter program set mode. and 55 flash. 2. Press or to adjust the exchange factor value. 3. Press to adjust the exchange factor value then press to return. 	
Fast Rinse Time	<ol style="list-style-type: none"> 1. In fast rinse time display status, it shows and 1-10:00. Press and enter program set mode. and 10:00 flash. 2. Press or to adjust the fast rinse time (minute). 3. Press and to finish adjustment then press to return. 	
Backwash Time	<ol style="list-style-type: none"> 1. In backwash time display status, it shows and 2-10:00. Press and enter program set mode. and 10:00 flash. 2. Press or to adjust the backwash time (minute). 3. Press and finish adjustment then press to return. 	







Brine & Slow Rinse Time	<p>1. In brine & slow rinse time display status, it shows  and 3-70:00. Press  and enter program set mode.  and 70:00 flash.</p> <p>2. Press  or  to adjust the brine time (minute).</p> <p>3. Press  and finish adjustment then press  to return.</p>	
Brine Refill Time	<p>1. In brine refill time display status, it shows  and 4-05:00. Press  and enter program set mode.  and 05:00 flash.</p> <p>2. Press  or  to modify the brine refill time (minute).</p> <p>3. Press  to finish adjustment then press  to return.</p>	
Maximum Interval Regeneration Days	<p>1. In maximum interval regeneration days display status, it shows H-30. Press  and enter program set mode.  and 30 flash.</p> <p>2. Press  or  to adjust the interval regeneration days.</p> <p>3. Press  to finish adjustment then press  to return.</p>	
Signal Output Mode	<p>1. In signal output mode display status, it shows b-01. Press  and enter program set mode.  and 01 flash.</p> <p>2. Press  or  to adjust the signal output mode (b-02).</p> <p>3. Press  to finish adjustment, then press  to turn back.</p>	

For example, the fast rinse time of a softener is 12 minutes. After regeneration, the chloridion in the outlet water is always higher than normal, indicating that there is not enough time for fast rinse. If you want the time to set to 15 minutes, the modification steps as follows:

- ① Press and hold both  and  to unlock the button ( lights off)
- ② Press  , and  lights on.
- ③ Press  or  continuously until  lights on. Then the digital area shows: 1-12:00M.
- ④ Press  ,  and 12 flash.
- ⑤ Press  continuously until 12 is changed to 15.
- ⑥ Press  , there is a sound “Di” and the figure stop flashing; the program back to enquiry status.
- ⑦ If you want to adjust other parameters, you can repeat the steps from ② to ⑤. If you don't, press  and quit from the enquiry status, the display will show the current service status.

3.6 Trial running

After installing the multi-functional flow control valve on the resin tank with the connected pipes, as well as setting up the relevant parameter, please conduct the trial running as follows:

1. Make U2 tank in “Standby” position and U1 tank in “Service” position
2. Slowly open the inlet valve to 1/4 position, making the water flows into the U1 resin tank; After all air is out of pipeline, close the outlet valve and check if there is a leakage, if yes, solve the problem immediately.
3. Fully opened the inlet valve.
4. Press  button to make valve switch U2 tank into fast rinse position and U1 tank is in service position. To make sure water flows out from drain for 8~15 minutes.
5. Press  button to make valve switch U2 tank into service position and U1 tank is in backwash position. At this time, wash the resin impurities in the U1 tank until the drainage pipe discharged the clarified water, the time is about 8~10 minutes.
6. Using hose or measure implement add water to brine tank until water reach to the top of air check valve. Then add required salt into brine tank as make it dissolved as far as possible.
7. Press button  to make valve turn to brine & slow rinse position to regenerate U1 tank. Air check valve turns off and valve turns to slow rinse process for several minutes (namely slow rinse).
8. Press button  to make valve turn to “brine refill” position.
9. Press button  to make U1 tank turn to “standby” position.
10. Press button  to make U1 tank turn to “fast rinse” position, it takes about 8~15 minutes.
11. Take out some outlet water for testing. If it is qualified, press button  to switch U1 tank in “service”, U2 tank in “backwash” position. To make sure water flows out from drain for 8~10 minutes.
12. Repeat above step 7 to step 9 to make U1 tank in “service” position, U2 tank in “standby” position. Then system can be come into use.

Notice:

- If water inflows too fast, the media in tank will be damaged. When water inflows slowly, there is a sound of air emptying from drain pipeline.
- After changing resin, please empty air in the resin according to the above Step 3.
- In the process of trial running, please check the water situation in all positions, ensuring there is no resin leakage.
- The time for Backwash, Brine & Slow Rinse, Brine Refill and Fast Rinse positions can be set and executed according to the calculation in the formula or suggestions from the control valve suppliers.

3.7 In the process of trial running, please check the water situation in all positions, ensuring there is no resin leakage.

A. Control Valve Fault

Problem	Cause	Correction
1. Softener fails to regenerate.	A. Electrical service to unit has been interrupted. B. Regeneration cycles set incorrect. C. Controller is defective. D. Motor fails to work.	A. Assure permanent electrical service (Check fuse, plug, pull chain or switch). B. Reset regeneration time. C. Check or replace controller. D. Check or replace motor.
2. Softener supply hard water.	A. Bypass valve is opened or leaking. B. No salt in brine tank. C. Injector is plugged. D. Insufficient water flows into brine tank. E. Leak at O-ring on riser pipe. F. Internal valve leaks.	A. Close or repair bypass valve. B. Add salt to brine tank and maintain salt level above water level. C. Change or clean injector. D. Check brine tank refill time. E. Make sure riser pipe and O-ring is not cracked. F. Check valve body and change if necessary.
3. Softener fails to draw brine.	A. Inlet line pressure is too low. B. Brine line is plugged. C. Brine line is leaking. D. Injector is plugged or broken down. E. Internal control valve leaks.	A. Increase inlet line pressure. B. Clean brine line. C. Replace brine line. D. Clean or replace injector. E. Check valve body and change if necessary.
4. Excessive water in brine tank.	A. Overlong brine refill time. B. Remain too much water after brine draw.	A. Reset correct brine refill time. B. Check the injector and make sure no stuff in the brine pipe.
5. Pressure lost	A. Rust in the water supply pipe. B. Rust mass in the softener.	A. Clean the water supply pipe. B. Clean valve and add resin cleaning chemical, increase frequency of regeneration.
6. Loss of resin through drain line	A. Air in water system.	A. Exhaust air exist in system.
7. Control cycle continuously.	A. Locating signal wiring breaks down. B. Controller is faulty. C. Foreign material stuck the driving gear.	A. Check and connect locating signal wiring. B. Replace controller. C. Take out foreign material.
8. Drain flows continuously.	A. Internal valve leaks. B. Power off when valve is in backwash or fast rinse status.	A. Check and repair valve body or replace it. B. Adjust valve to service position or turn off bypass valve and restart after electricity supply is normal.

B. Controller Fault

Problem	Cause	Correction
1. All indicators display on front panel.	A. Wire of display board is damaged. B. Control board is faulty. C. Transformer is damaged. D. Electrical service is not stable.	A. Check and replace the wire of display board. B. Replace control board. C. Check and replace transformer. D. Check and adjust electrical service.
2. No display on front panel.	A. Wire of display board is damaged. B. Display board is damaged. C. Control board is damaged. D. Electricity is interrupted.	A. Check and replace wire of display board. B. Replace display board. C. Replace control board. D. Check electricity.
3. E11 Flash	A. Wire of locating board is damaged. B. Locating board is damaged. C. Mechanical driven failure. D. Control board is damaged. E. Wire of tank alternated motor is broken. F. Tank alternated motor is damaged.	A. Replace wire of locating board. B. Replace locating board. C. Check and repair mechanical part. D. Replace control board. E. Replace wire of tank alternated motor. F. Replace tank alternated motor.
4. E21 Flash	A. Wire of locating board is damaged. B. Locating board is damaged. C. Mechanical driven failure. D. Control board is damaged. E. Wire of regeneration motor is broken. F. Regeneration motor is damaged.	A. Replace wire of locating board. B. Replace locating board. C. Check and repair mechanical part. D. Replace control board. E. Replace wire of regeneration motor. F. Replace regeneration motor.
5. E12 or E22 Flash	A. Hall component on locating board is damaged. B. Wire of locating board is broken. C. Control board is faulty.	A. Replace locating board. B. Replace wire of locating board. C. Replace control board.
6. E3 or E4 Flash	A. Control board is faulty.	A. Replace control board.

Note: " Tank alternated motor" refers to the motor close to the outlet, and " regeneration motor " refers to the motor close to the injector.

MODEL: F135/17610T-F137/17606T

3.8 Assembly & Parts

17610T Valve Body Assembly:

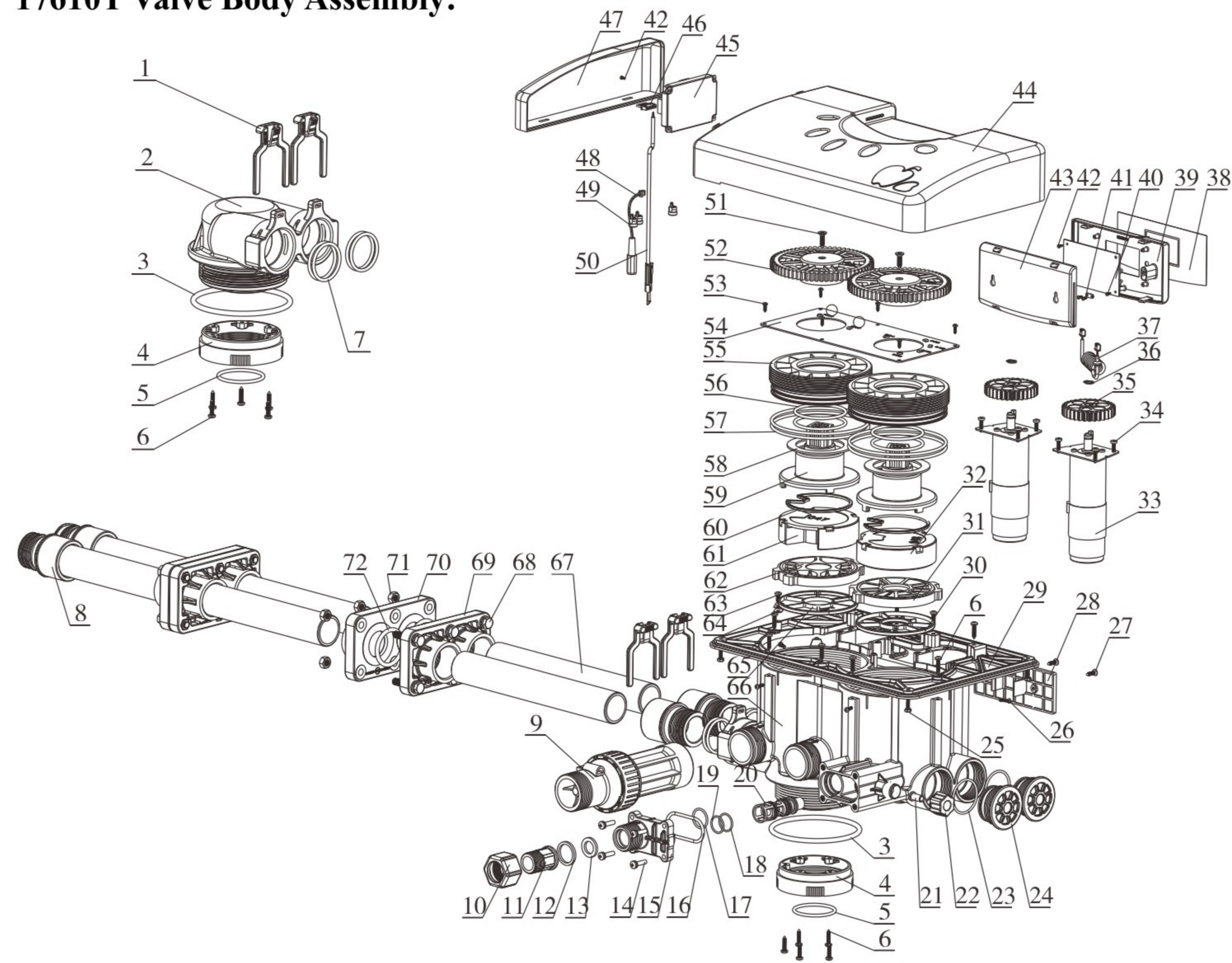

Component and part No. for 17610T:

Item No.	Description	Part No.	Quantity
1	Clip	8270031	4
2	Valve Body	5022204 (GB Standard)	1
		5022204A (US Standard)	
3	O-ring $\phi 104.6 \times 5.7$	8378146	2
4	Connector	8458018	2
5	O-ring 50.47×2.62	8378308 (GB Standard)	2
		8378124 (US Standard)	
6	Screw, Cross ST 3.9×19	8909003	19
7	O-ring 38.7×3.55	8378184	8
8	Joint	8458294	4

MODEL: F135/17610T-F137/17606T

9	Flow Meter	5447010	1
10	Animated Connector	8945043	1
11	Joint	8458219	1
12	Sealing Washer	8371053	1
13	DLFC	Without (default)	1
14	Screw, Cross M5 $\times 20$	8902064	4
15	Cover, Injector	8315159	1
16	O-ring 45×3.55	8378312	1
17	O-ring 22×2.2	8378351	1
18	O-ring 20×1.8	8378024	1
19	O-ring 19×1.8	8378021	1
20	Injector	5468032 (default)	1
21	Tube	8457025	1
22	Hexagonal Nut	8940016	1
23	O-ring 40×2.65	8378091	2
24	Plug	8323009	2
25	Screw, Cross ST 3.9×16	8909016	4
26	Screw, Cross ST 2.9×13	8909023	4
27	Screw, Cross ST 3.9×16	8909014	2
28	Display Holder	8040003	1
29	Connecting Board	8152112	1
30	Sealing Ring	8370153	1
31	Fixed Disk	8469045	1
32	Moving Disk	8459048	1
33	Motor	6158039	2
34	Screw, Cross ST 3.9×16	8909044	8
35	Small Gear	5241008	2
36	Pin	8994009	2
37	Three-core Spring	5517001	1
38	Sticker	8865011	1
39	Display Cover	8300013	1
40	Display Board	6381007	1
41	Wire Clip	8126001	1
42	Screw, Cross ST 2.2×6.5	8909004	6

MODEL: F135/17610T-F137/17606T

43	Display Cover	8315008	1
44	Dust Cover	8005029	1
45	Control Board	6382019	1
46	Wire for Locating Board	5511010	1
47	Front Cover	8300028	1
48	Wire for Power	5513001	1
49	Wire Clip	8126004	3
50	Probe Wire	6386009	1
51	Screw, Cross ST 4.8×19	8909018	2
52	Big Gear	5241025	2
53	Screw, Cross ST 2.9×9.5	8909008	6
54	Locating Board	6380079	1
55	Fitting Nut	8092032	2
56	O-ring 59.92×3.53	8378110	4
57	O-ring 117.6×3.55	8378133	4
58	Anti-friction Washer	8216006	2
59	Shaft	8258005	2
60	Moving Seal Ring	8378018	2
61	Moving Disk	8459047	1
62	Fixed Disk	8469044	1
63	Screw, Cross ST 3.9×13	8909013	1
64	Wire Clip	8126002	1
65	Seal Ring	8370071	1
66	Valve Body	5022180 (GB Standard) 5022180A (US Standard)	1
67	Pipe	8457205	6
68	Screw, Cross M8×40	8920008	12
69	Flange Connector	8458337	2
70	Flange Connector	8458338	2
71	Hexagonal Nut M8	8940021	12
72	O-ring 40×5	8378374	4

MODEL: F135/17610T-F137/17606T

17606T Valve Body Assembly:

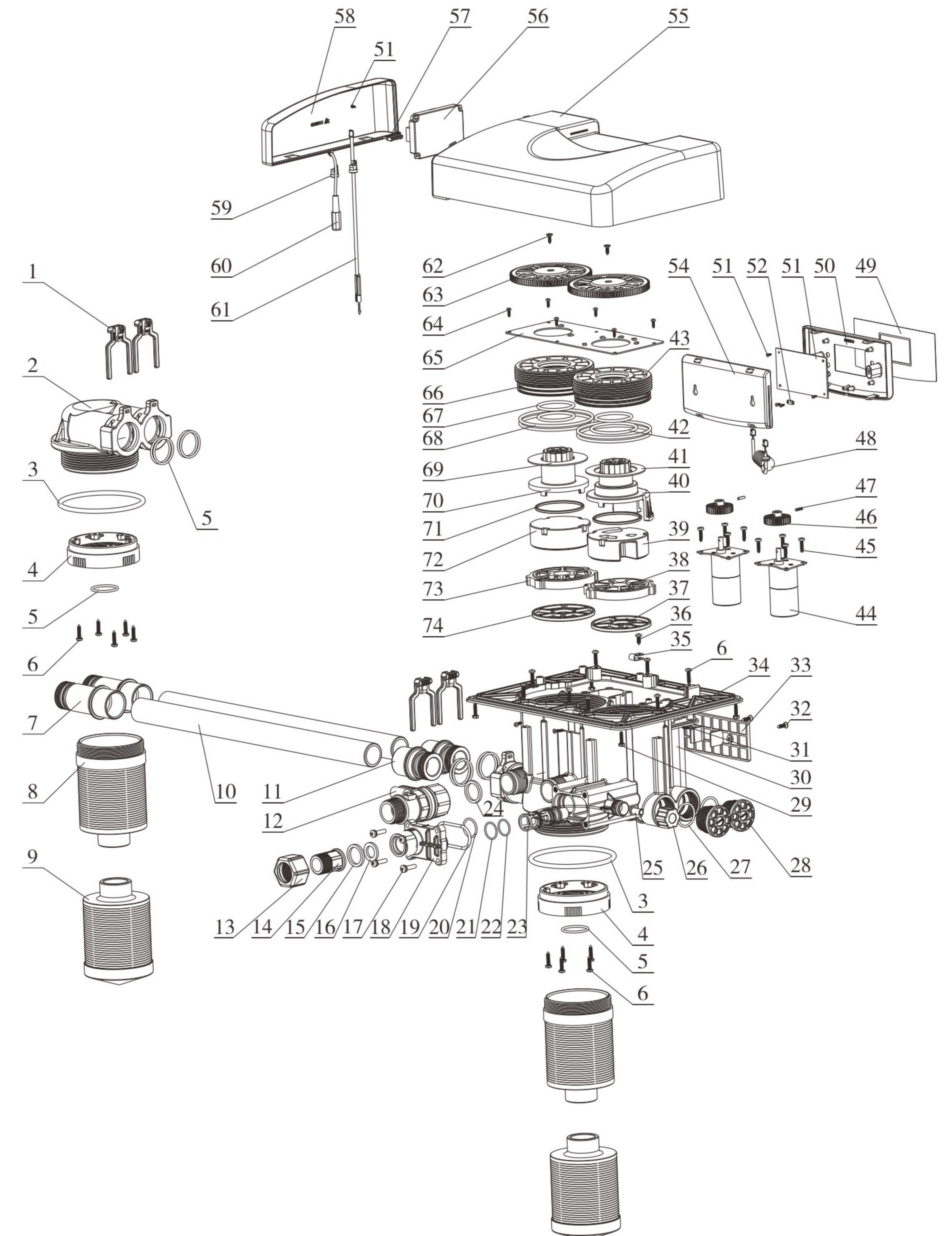

MODEL: F135/17610T-F137/17606T

Component and part No. for 17606T:

Item No.	Description	Part No.	Quantity
1	Clip	8270038	4
2	Valve Body	8022298	1
3	O-ring 104.6 × 5.7	8378146	2
4	Connector	8458018	2
5	O-ring 31.42 × 2.62	8378065	10
6	Screw, Cross ST3.9 × 19	8909003	18
7	Joint	8458374	2
8	Top Strainer	2976288	2
9	Bottom Strainer	2976289	2
10	Pipe	8457213	2
11	Joint	8458373	2
12	Flow Meter	5447018	1
13	Animated Nut	8945043	1
14	Joint	8458219	1
15	Seal Washer	8371053	1
16	DLFC	8468008~011	1
17	Screw, Cross M5 × 20	8902064	4
18	Injector Cover	8315159	1
19	O-ring 45 × 3.55	8378312	1
20	O-ring 22 × 2.2	8378351	1
21	O-ring 20 × 1.8	8378024	1
22	O-ring 19 × 1.8	8378021	1
23	Injector	5468031 (default)	1
24	Seal Washer	8371001	1
25	Tube	8457025	1
26	Hexagonal Nut	8940016	1
27	O-ring 28 × 2.65	8378081	2
28	Plug	8323059	2
29	Screw, Cross ST3.9 × 16	8909016	4
30	Valve Body	5022237	1
31	Screw, Cross ST2.9 × 13	8909023	4
32	Screw, Cross ST3.9 × 16	8909014	2

MODEL: F135/17610T-F137/17606T

33	Display Holder	8040003	1
34	Connecting Board	8152124	1
35	Wire Clip	8124002	1
36	Screw, Cross ST3.9 × 13	8909013	1
37	Seal Ring	8370174	1
38	Fixed Disk	8469056	1
39	Moving Disk	8459055	1
40	Shaft	8258030	1
41	Anti-friction Washer	8261052	1
42	O-ring 56 × 3.55	8378313	1
43	Fitting Nut	8092062	1
44	Motor	6158101	2
45	Screw, Cross ST3.9 × 16	8909044	8
46	Small gear	8241012	2
47	Pin φ2.5 × 12	8993003	2
48	Three-core Spring	5517001	1
49	Sticker	8865001	1
50	Display Cover	8300013	1
51	Display Board	6381007	1
52	Wire Clip	8826001	1
53	Screw, Cross ST2.2 × 6.5	8909004	6
54	Display Cover	8315008	1
55	Dust Cover	8005011	1
56	Control Board	6382019	1
57	Wire for Locating Board	5511010	1
58	Front Cover	8300012	1
59	Wire Clip	8126004	2
60	Wire for Power	5513001	1
61	Probe Wire	6386014	1
62	Screw, Cross ST3.9 × 13	8909012	2
63	Gear	5241027	2
64	Screw, Cross ST2.9 × 9.5	8909008	6
65	Locating Board	8380084	1
66	Fitting Nut	8092037	1

MODEL: F135/17610T-F137/17606T

67	O-ring 43.7 × 3.55	8378123	3
68	O-ring 92.5 × 3.55	8378199	4
69	Anti-friction Washer	8216051	1
70	Shaft	8258014	1
71	Moving Seal Ring	8370065	2
72	Moving Disk	8459054	1
73	Fixed Disk	8469055	1
74	Seal Ring	8370083	1

MODEL: F135/17610T-F137/17606T

Flow Meter Connector Structure:

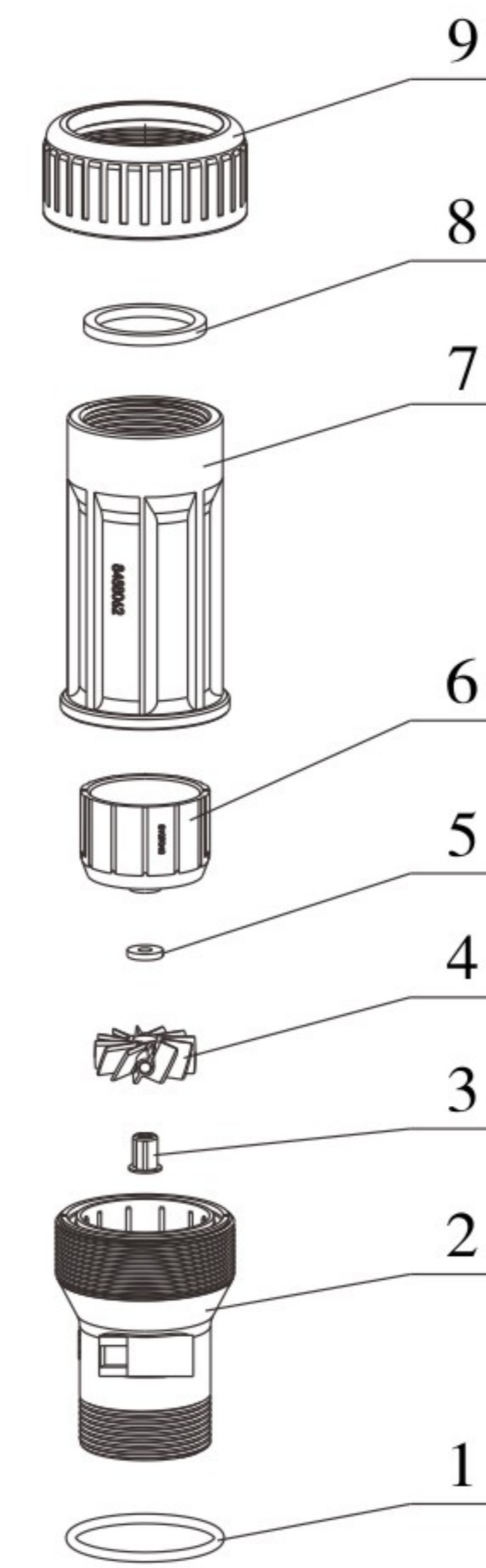

5447010 Flow meter

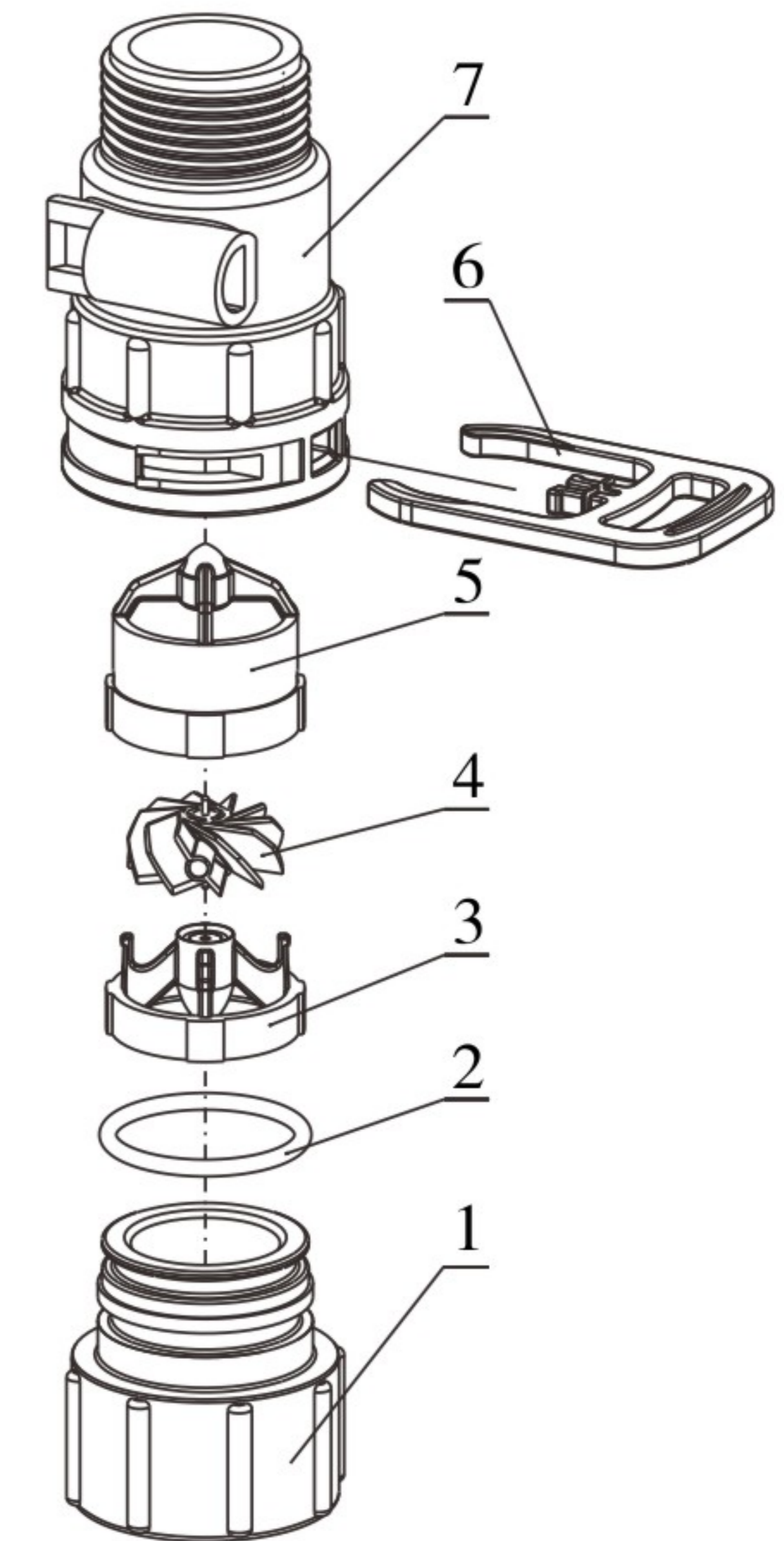

5447018 Flow meter

Flow Meter Connector Part No.:

5447010 Flow meter				5447018 Flow meter			
Item No.	Description	Part No.	Quantity	Item No.	Description	Part No.	Quantity
1	O-ring	8378107	1	1	Animated Nut	8945001	1
2	Shell	5002004	1	2	O-ring	8378081	1
3	Rotating Core	8211003	1	3	Impeller Support	5115022	1
4	Turbine	5436009	1	4	Turbine	5436010	1
5	Busher	8210002	1	5	Impeller Support	5115021	1
6	Connector	8109040	1	6	Clip	8270004	1
7	Fix Holder	8458062	1	7	Shell	8002001	1
8	Seal Washer	8371030	1				
9	Animated Nut	8947023	1				

4. Warranty Card

Dear client:

This warranty card is the guarantee proof of Runxin brand multi-functional flow control valve. It is kept by client self. You could get the after-sales services from the supplier which is appointed by Runxin manufacturer. Please keep it properly. It couldn't be retrieved if lost. It couldn't be repaired free of charge under the below conditions:

1. Guarantee period expired.(One year);
2. Damage resulting from using, maintenance, and keeping that are not in accordance with the instruction;
3. Damage resulting from repairing not by the appointed maintenance personnel;
4. Content in guarantee proof is unconfirmed with the label on the real good or be altered;
5. Damage resulting from force majeure.

Product Name	 Multi-functional Flow Control Valve for Water Treatment Systems			
Model		Code of Valve Body		
Purchase Company Name		Tel/Cel.		
Problem				
Solution				
Date of Repairing		Date of Accomplishment		Maintenance Man Signature

When product needs warranty service, please fill in the below content and send this card together with the product to the appointed suppliers or Runxin company.

End-user Company Name		Tel/Cel.		
Purchase Company Name		Tel/Cel.		
Model		Code of Valve Body		
Tank Size ϕ ×		Resin Volume L	Raw Water Hardness	mmol/L
Water Source: Ground-water <input type="checkbox"/> Tap Water <input type="checkbox"/>		Water Treatment Capacity m^3	Backwash Time	min
Brine & Slow Rinse Time min		Brine Refill Time min	Fast Rinse Time	min
Problem Description				