



## Multi-functional Flow Control Valve for Water Treatment Systems

53502 (Old Model No.:F71B1)

53502B (Old Model No.:F71G1)

53504S/53506S (Old Model No.:F67B1/F67B1-A)

53504 (Old Model No.:F67C1)

53504B (Old Model No.:F67G1)

53510 (Old Model No.:N75A1)

53510B (Old Model No.:N75B1)

## Instruction Manual

### **WENZHOU RUNXIN MANUFACTURING MACHINE CO.,LTD**

ADD: NO.169, RUNXIN ROAD, SHANFU TOWN, WENZHOU, ZHEJIANG, CHINA.

TEL.:0086-577-88630038, 88576512, 85956057 FAX:0086-577-88633258

E-MAIL: sales@run-xin.com <http://www.run-xin.com>

Rev.A.2403



Please read this manual in details  
before using this valve and keep it properly  
in order to consult in the future

0WRX.466.508

MODEL: F71B/F71G/F67B/F67C/F67G/N75A/N75B

Before the valve put into use, please fill in the below content so as to help us to refer in the future.

**Filter System Configuration**

Tank size: Dia. \_\_\_\_\_ mm; Height \_\_\_\_\_ mm;  
Refilled filter materials \_\_\_\_\_ Kg; Granularity of filter materials \_\_\_\_\_ mm;  
Control valve model \_\_\_\_\_ ; Number \_\_\_\_\_ ;  
Pressure of inlet water \_\_\_\_\_ MPa; Turbidity of inlet water \_\_\_\_\_ FTU.  
Water source: Ground-water ; Filtered ground-water ;  
Tap water ; Other \_\_\_\_\_ .

**Parameter Set**

Parameter	Unit	Factory Default	Actual Value
Time of Day	h:m	Random	
Service Days (Time clock type, by days)	D.	03	
Service Hours (Time clock type, by hours)	H.	20	
Rinsing Time	/	02:00	
Rinsing Frequency	/	F-00	
Backwash Time	min:sec	10:00	
Fast Rinse Time	min:sec	10:00	
Output Mode b-01(02)	/	b-01	

## Catalogue

Notice.....	3
1. Product Overview.....	4
1.1. Main Application & Applicability.....	4
1.2. Product Characteristics.....	4
1.3. Service Condition.....	6
1.4. Product Structure and Technical Parameters.....	6
1.5. Installation.....	8
2. Basic Setting & Usage.....	10
2.1. The Function of PC Board.....	10
2.2. Basic Setting & Usage.....	12
3. Applications.....	14
3.1. Filter Flow Chart.....	14
3.2. The Function and Connection of PC Board.....	16
A. Signal Output Connector.....	17
B. Interlock.....	20
C. Pressure Relief Connector.....	21
D. Remote Handling Connector.....	21
3.3. System Configuration and Flow Rate Curve.....	22
3.4. Parameter Enquiry and Setting.....	24
3.5. Trial Running .....	26
3.6. Trouble-Shooting.....	27
3.7. Assembly & Parts.....	29
4. Warranty Card.....	45

## Notice

- To ensure normal operation of the valve, please consult with professional installation or repairing personnel before use it.
- If there are any of pipeline engineering and electric works, there must be finished by professional at the time of installation.
- Do not use the control valve with the water that is unsafe or unknown quality.
- Depending on the changing of working environment and water requirement, each parameter of filter should be adjusted accordingly.
- Test water periodically to verify that system is performing satisfactorily.
- Do not put the valve near the hot resource or surroundings with high humidity, corrosive, intense magnetic field or intense vibrations environment. And do not leave it outside.
- Forbidden to use the drain pipeline or other connectors as support to carry the system.
- Please use this product under the water temperature between 5~50°C, water pressure 0.15~0.6MPa. Failure to use this product under such conditions voids the warranty.
- If the water pressure exceeds 0.6MPa, a pressure reducing valve must be installed in front of the water inlet. While, if the water pressure is under 0.15MPa, a booster pump must be installed in front of the water inlet.
- Do not let children touch or play, because careless operation may cause the procedure changed.
- When the attached cables or transformer of this product are broken, they must be changed to the one that is from our factory.
- For 53510 (N75A1) and 53510B (N75B1) product, in order to disassemble easily, it is suggested to install the strainer with M88×2 male thread.
- At the end of the product lifetime, parts and components of the product are sorted and properly disposed in accordance with local laws and regulations.

## 1. Product Overview

### 1.1. Main Application & Applicability

Used for filtering water treatment systems

Be suitable for residential filtering system

Swimming pool filtering equipment (N75A1/53510, N75B1/53510B)

Carbon filter or sand filter in RO pretreatment filtering system

### 1.2. Product Characteristics

#### ● Simple structure and reliable sealing

It adopts hermetic head faces with high degree pottery and corrosion resistance for opening and closing. It combines with Service, Backwash, and Fast Rinse.

#### ● No water passes the valve in rinsing in single tank type

#### ● Manual function

Realize rinsing immediately by pressing  at any time.



#### ● Long outage indicator

If outage overrides 3 days, the time of day indicator "12:12" will flash to remind people to reset new time of day. The other set parameters do not need to reset. The process will continue to work after power on.

#### ● LED dynamic screen display

The stripe on dynamic screen flash, it indicates the control valve is in service; otherwise, it is in rinsing cycle.

#### ● Buttons lock

No operations to buttons on the controller within 1 minute, button lock indicator lights on which represent buttons are locked. Before operation, press and hold the  and  buttons for 5 seconds to unlock. This function can avoid incorrect operation.

#### ● Rinsing frequency

It could set up multiple rinsing times, which means several times of backwash and fast rinse but one time of service (Can be adjusted). It is much better for cleaning the filter materials (Refer to P25 for detailed setting method).

#### ● There are two kinds of time clock types

Time clock type valve can be chosen to be service by hours, by dialing the red switch on main control board to "1" (Refer to the Figure 3-1). Pointing to "ON" mean the time clock type service by days; "1" means the time clock type service by hours.

(Attention: after dialing the switch, please restart the power)

#### ● Interlock function

It has a function of interlock to realize only one valve in regeneration or rinsing, but the other valves are in service while there are several valves parallel in system. In multi-steps treatment systems such as RO pre-treatment, when several valves are in series, there is only one valve in rinsing to ensure pass water all the times while different valves in rinsing. (Application refer to Figure 3-10)

#### ● Signal output

There is a signal output connector on main control board. It is applied for controlling external wiring (Refer to Figure from Figure 3-2 to Figure 3-9).

There are two kinds of output modes. b-01 Mode: Turn on when start regeneration and shut off end of regeneration; b-02 Mode: Signal is available only at intervals of each status. Refer to below figures:

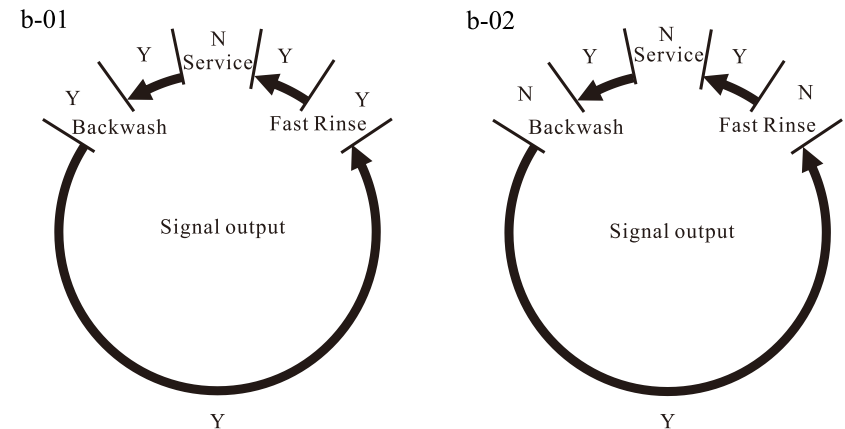

#### ● Remote handling connector

This connector can receive external signal, used together with PLC, and computer etc. to control the valve remotely. (Application refer to Figure 3-12)

#### ● Pressure relief connector

The valve will cut off feeding water to drain line when it switches in rinsing cycles (Same as signal output b-02). Thus in some water treatment system, e.g. Deep Well, one booster pump was installed on the inlet to increase the system water feeding pressure, this cut-off will cause pressure on inlet rising too fast to damage the valve. Pressure Relief Output can be used to avoid this problem. (Application refers to Figure 3-11).

#### ● All parameters can be modified

According to the water quality and usage, the parameters in the process can be adjusted.

**MODEL: F71B/F71G/F67B/F67C/F67G/N75A/N75B**

**1.3. Service Condition**

Filter Valve should be used under the below conditions:

Items		Requirement
Working Conditions	Water Pressure	0.15MPa ~ 0.6MPa
	Water Temperature	5°C ~ 50°C
Working Environment	Environment Temperature	5°C ~ 50°C
	Relative Humidity	≤ 95% (25°C)
	Electrical Facility	AC100 ~ 240V/50 ~ 60Hz
Inlet Water Quality	Water Turbidity	< 20FTU

**Note:**

● When the water turbidity exceeds the conditions, the impurity in the inlet water should be coagulated and precipitated firstly.

**1.4. Product Structure and Technical Parameters**

Dimension (The appearance is just for reference. It is subjected to the real product)

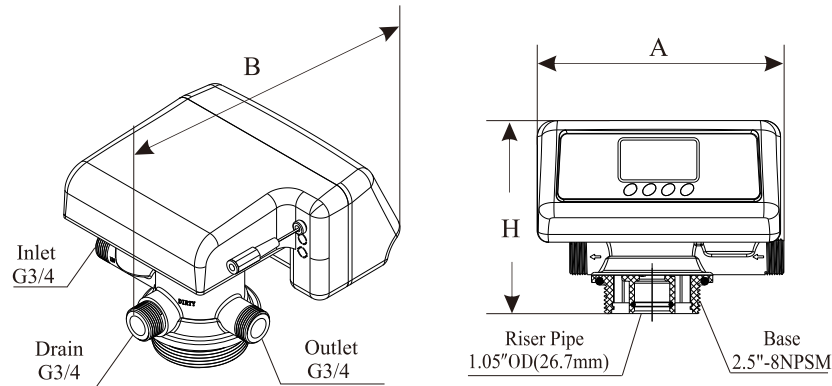

Model	A(mm) max	B(mm) max	H(mm) max	Transformer Output	Flow Rate m <sup>3</sup> /h @0.3MPa
F71B1(53502)	182.5	195.5	143	DC12V, 1.5A	2.0
F71G1(53502B)	199	180	167		

**MODEL: F71B/F71G/F67B/F67C/F67G/N75A/N75B**

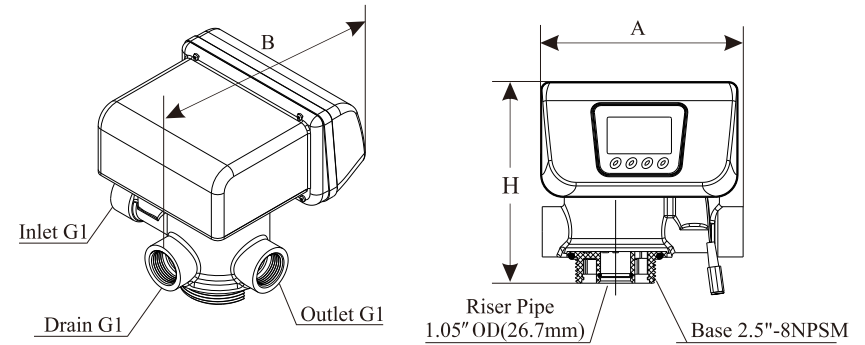

Model	A(mm) max	B(mm) max	H(mm) max	Transformer Output	Flow Rate m <sup>3</sup> /h @0.3MPa
F67B1-A(53506S)	180	194	190	DC12V, 1.5A	6.0
F67B1(53504S)			181		4.0
F67C1(53504)					
F67G1(53504B)	242	204	198		

The diameter of riser pipe for F67B1, F67C1, F67G1 is 1.05"OD (26.7mm)

The diameter of riser pipe for F67B1-A is 1"D-GB (32mm)

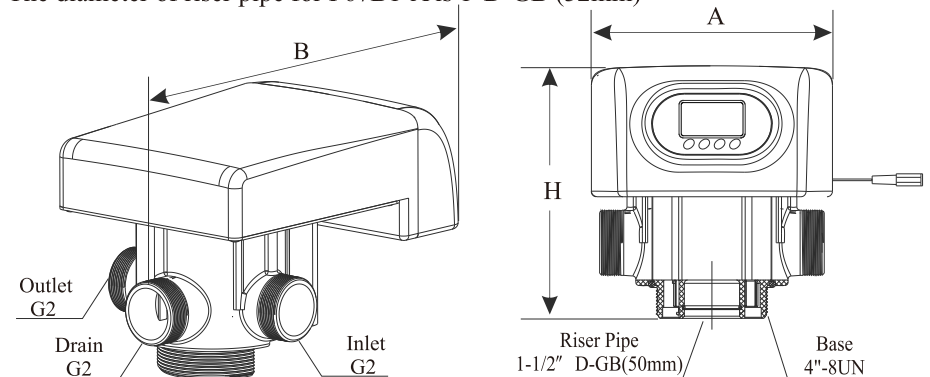

Model	A(mm) max	B(mm) max	H(mm) max	Transformer Output	Flow Rate m <sup>3</sup> /h @0.3MPa
N75A1(53510)	220	346.5	230.5	DC24V, 1.5A	10.0
N75B1(53510B)	216.5	346.5	247		

## 1.5. Installation

### A. Installation notice

Before installation, read all those instructions completely. Then obtain all materials and tools needed for installation.

The installation of product, pipes and circuits, should be accomplished by professional to ensure the product can operate normally.

Perform installation according to the relative pipeline regulations and the specifications of Water Inlet, Water Outlet, and Drain Outlet.

### B. Device location

- ① The filter should be located closely to drain.
- ② Ensure the unit is installed in enough space for operating and maintenance.
- ③ The unit should be kept away from the heater, and not be exposed to outdoor. Sunshine or rain will cause the system damage.
- ④ Please avoid to installing the system in one acid/alkaline, magnetic or strong vibration circumstance, because above factors will cause the system disorder.
- ⑤ Do not install the filter, drain pipeline in circumstance which temperature may drop below 5°C, or above 50°C.
- ⑥ Install the system in the place where with minimum loss in case of water leaking.

### C. Pipeline installation (Taking F71B for example)

#### ① Install control valve

a. As the Figure 1-1 shows, select the relevant riser pipe, glue the riser pipe to the bottom strainer and put it into the mineral tank, cut off the exceeding tube out of tank top opening and round it. Plug the riser pipe in case of mineral entering.

b. Fill the filter materials to the tank, and the height is accordance with the design code.

c. Insert the top strainer to the valve.

d. Install the top strainer to the valve and insert the riser pipe into control valve and screw tight control valve.

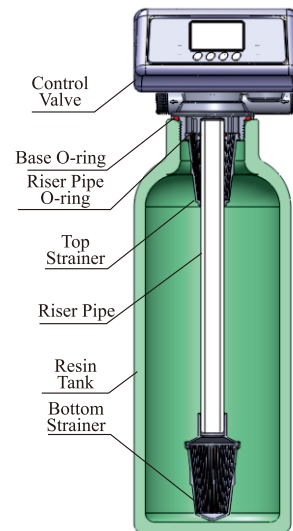

Figure 1-1

### Note:

- The length of riser pipe should be neither higher 1mm nor lower 5mm than tank top opening height, and its top end should be rounded to avoid damage of O-ring inside the valve.
- Avoid filling floccules substance together with filter materials to the tank.
- Avoid O-ring inside control valve falling out while rotating it on the tank.

#### ② Pipeline connection

a. As Figure 1-2 shows, install a pressure gauge in water inlet.

b. Install valve A, valve B, valve C and valve D in the inlet and outlet pipeline. The valve D is sampling valve.

c. Install the check valve in the outlet pipeline.

d. Inlet pipeline should be in parallel with outlet pipeline. Support inlet and outlet pipeline with fixed holder.

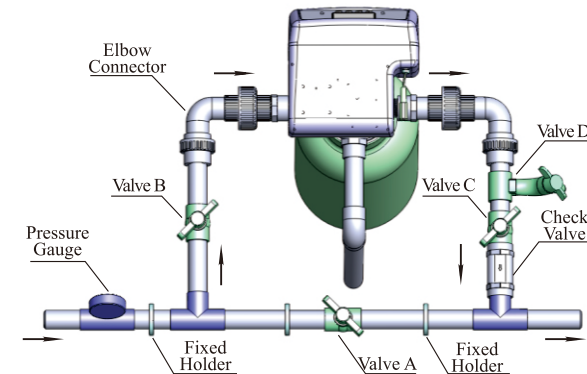

Figure 1-2

### Note:

- If making a soldered copper installation, do all sweat soldering before connecting pipes to the valve. Torch heat will damage plastic parts.
- When turning threaded pipe fittings onto plastic fitting, use care not to cross thread or broken valve.

③ Install drain pipeline

Directly connect the drain with the rigid pipeline, such as UPVC, etc.

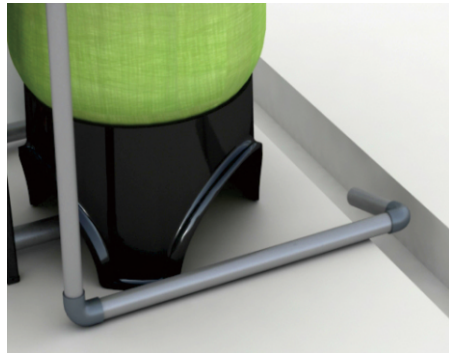

Figure 1-3

**Note:**

- Control valve should be higher than drain outlet, and be better not far from the drain hose.
- Be sure not connect drain with sewer directly, and leave a certain space between them (As the Figure 1-3 shows), avoid waste water being absorbed to the water treatment equipment.
- If waste water is used for other purpose, please use another container for loading. And also keep a certain space between drain and container.

## 2. Basic Setting & Usage

### 2.1. The Function of PC Board

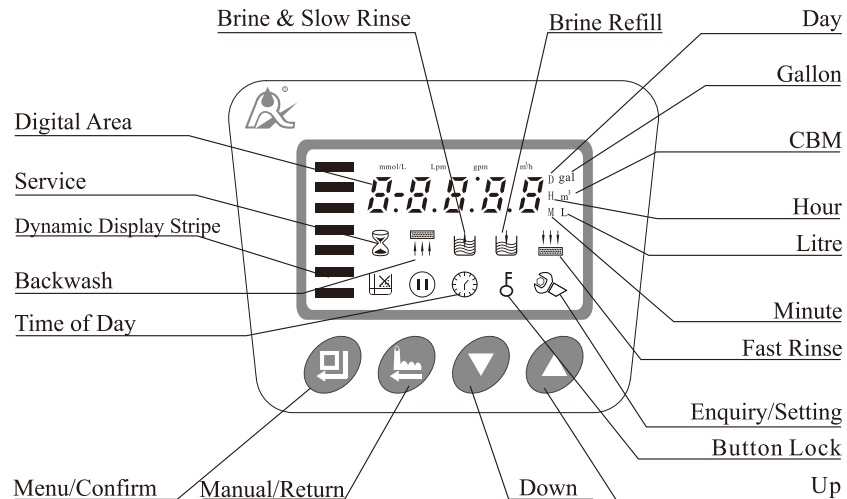

**A. ⌚ Time of Day indicator**

- ⌚ Lights on, indicate the time of day.

**B. 🔒 Button lock indicator**

- 🔒 Lights on, indicate the buttons are locked. At this moment, press any single button will not work (No operation in one minute, 🔒 will light on and lock the buttons.)
- Solution: Press and hold both ▼ and ▲ for 5 seconds until the 🔒 lights off.

**C. ⏪ Program mode indicator**

- ⏪ Lights on, enter program display mode. Use ▼ or ▲ to view all values.
- ⏪ Flashes and enter program set mode. Press ▼ or ▲ to adjust values.

**D. ⏪ Menu/Confirm button**

- Press ⏪, ⏪ lights on, enter program display mode and use ▼ or ▲ to view all values.
- In program display mode, press ⏪, ⏪ flashes, enter program set mode, press ▼ or ▲ to adjust values.
- Press ⏪ after all program are set, and then the voice "Di" means all setting are success and return program display mode.

**E. ⏪ Manual/Return button**





- Press ⏪ in working conditions, it can proceed to next step. (Example: if the outlet water is unqualified, you can press ⏪ to end the service and start an immediate rinsing. During the process of rinsing, pressing the ⏪ button can end one step in advance and proceed to the next step.)
- Press ⏪ in program display mode, and it will return to Service. Press ⏪ in program set mode, and it will return to program display mode.
- Press ⏪ while adjusting the value, then it will return program display mode directly without saving value.

**F. Down ▼ and Up ▲**

- In program display mode, press ▼ or ▲ to view all values.
- In program set mode, press ▼ or ▲ to adjust values.
- Press and hold both ▼ and ▲ for 5 seconds to unlock the Button Lock status.

2.2. Basic Setting & Usage (Take F67, F71 for example)

A.Parameter specification

Function	Indicator	Factory Default	Parameter Set Range	Instruction
Time of Day		Random	00:00~23:59	Set the time of day when use, ":" flashes
Service Days		1-03D.	0~99 Days	Only for Time Clock Type, by days
Service Hours		1-20H.	0~99 Hours	Only for Time Clock Type, by hours
Rinsing Time	02:00	02:00	00:00~23:59	Rinsing time; ":" lights on
Rinsing Frequency	F-00	00	0~20	Rinsing frequency. For example, F-01: indicate service 1 time, backwash and fast rinse 2 times;
Backwash Time		10:00	0~99:59	Backwash time (Minute), correct to second;
Fast Rinse Time		10:00	0~99:59	Fast Rinse Time (Minute), correct to second;
Output Control Mode	b-01	01	01 or 02	b-01: Signal turns on when start of rinsing and shut off at end of rinsing. (Connection refers to the Figure P5) b-02: Signal is only available at intervals of rinsing cycles and in service. (Connection refers to the Figure P5)

B.Process Display (Time Clock Type, by days)





Working status	The circular interface displays in turn	
Service		
Backwash		
Fast Rinse		

Illustration:

- The display screen will only show "-00-" when the electrical motor is running.
- The time of day figure  flashes continuously, such as "12:12" flashes, indicates long outage of power. It reminds to reset the time of day.
- The display will show the error code, such as "-E1-" when the system is in error.
- Working process: Service → Backwash → Fast Rinse

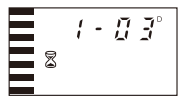
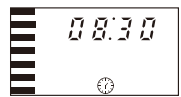
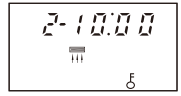

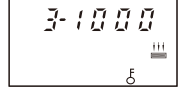
### 3. Applications

#### 3.1. Filter Flow Chart

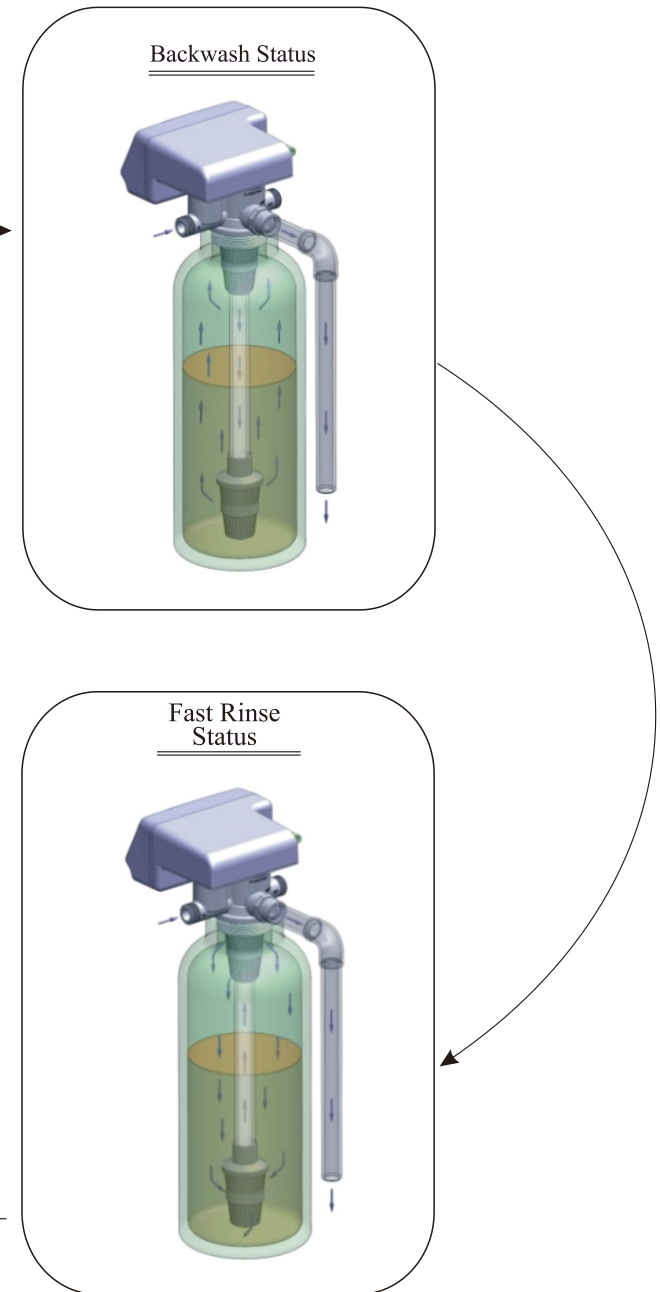
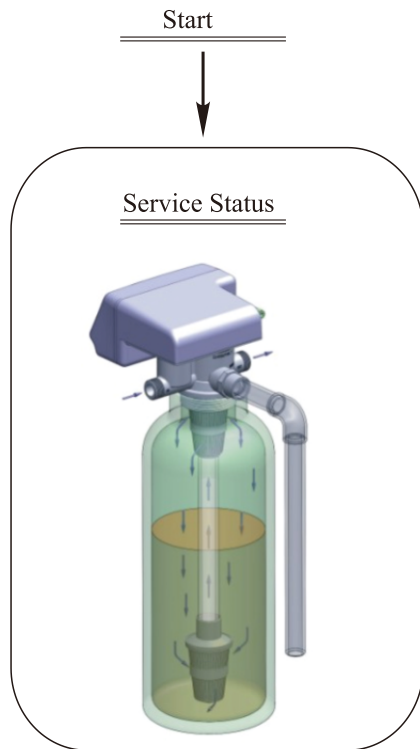

### 3.2. The Function and Connection of PC Board

Opening the front cover of control valve, you will see the main control board and connectors as Figure 3-1A shows (For F71, F67).

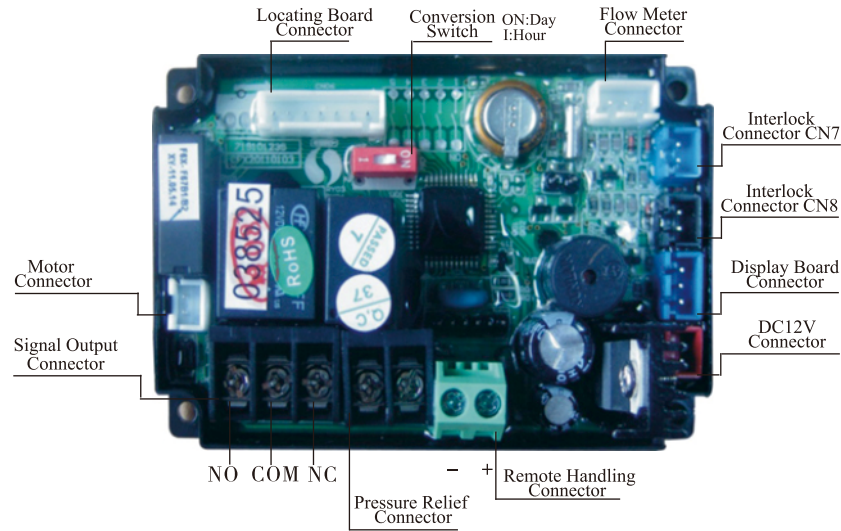

Figure 3-1A

The main control board and connection port for N75 as Figure 3-1B shows:

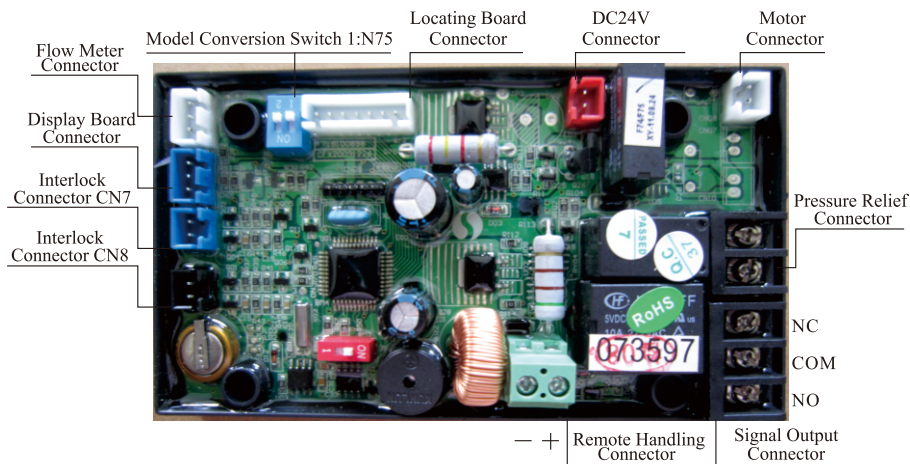

Figure 3-1B

The main functions on main control board:

Function	Application	Explanation
Signal output connector b-01	Outlet solenoid valve	Used in strict requirements regarding no hard water flows from outlet or controlling the liquid level in water tank.
	Inlet pump	Increase pressure for regeneration or rinsing. Use the liquid level controller to control inlet pump to ensure there is water in tank.
Signal output connector b-02	Inlet solenoid valve or inlet pump	When inlet pressure is high, it needs to close water inlet when valve is rotating prevent motor can't rotate.
Pressure relief connector	Control the inlet bypass to release pressure	Used for pump water supply. When valve is rotating, pressure relief connector opened to prevent pressure increasing rapidly.
Interlock connector	To ensure only one control valve rinsing in system.	Use in RO Pre-treatment, water supply together but rinsing in turn. Second grade ion exchange equipment, etc.
Remote handling connector	Receive signal to make the control valve rotate to next status.	It is used for on-line inspection system, connected with PC to realize automatically or remote controlling valve.

#### A. Signal Output Connector

1) Control Outlet Solenoid Valve (Set b-01)

① Solenoid Valve on Outlet Controls Water Level in Water Tank.

Instruction: If system strictly requires no unfiltered water flowing from outlet in rinsing cycle (Mainly for no unfiltered water flows out when valve is switching. When valve in backwash positions, there is no unfiltered water flows from outlet), a solenoid valve could be installed on outlet, the wiring refers to Figure 3-2.

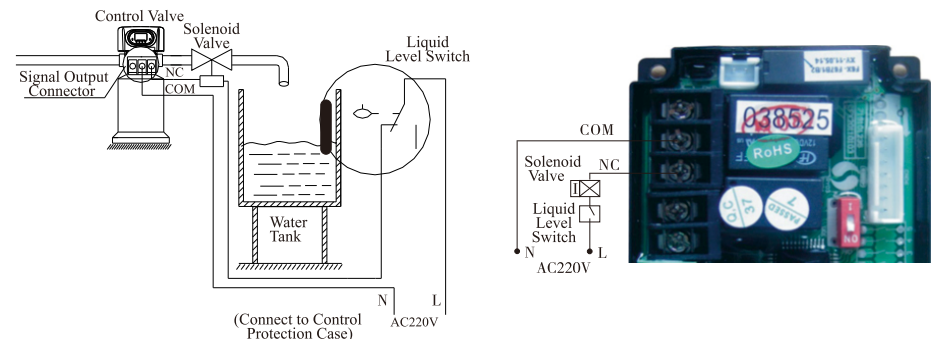

Figure 3-2 Wiring of Solenoid Valve on Outlet

**MODEL: F71B/F71G/F67B/F67C/F67G/N75A/N75B**

**Function:**

In service status, if water tank is short of water, solenoid valve will open to supply filtered water, but if water tank has enough water, solenoid valve will close, so no filtered water is supplied to the tank.

When the valve is in backwash status, there is no signal output. So, solenoid valve will close, and no raw water flows into the water tank.

**② Control Inlet Solenoid Valve (Set b-02)**

Instruction: When inlet pressure exceeds 0.6MPa, install a solenoid valve on inlet. Control mode is b-02. Pressure is relieved when valve is switching, the wiring refers to Figure 3-3. As Figure 3-4 shows, it also can use the pressure relief port to work.

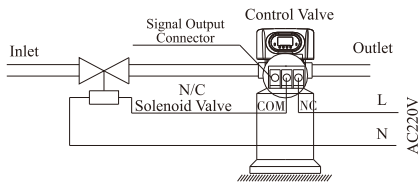

Figure 3-3 Wiring of Solenoid Valve on Inlet

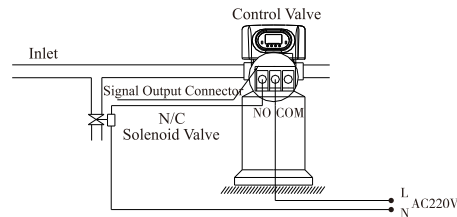

Figure 3-4 Wiring of Pressure Relief Port

**Function:**

When inlet pressure is high, install a solenoid valve on inlet to ensure valve switches properly. The solenoid valve will open when valve is exactly at status of Service, Backwash and Fast Rinse. When valve is switching, solenoid valve is closed, no water flows into valve to ensure valve switching properly. It could prevent the problem of mixing water and water hammer.

Use interlock cable to realize valves in parallel and series in same system which is suited for RO pretreatment system or second grade Na<sup>+</sup> system. The Wiring refers to Figure 3-5.

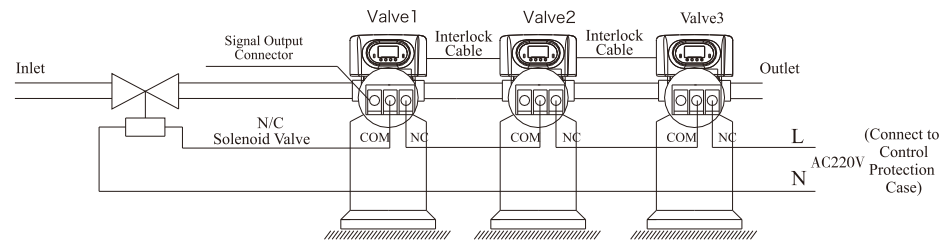

Figure 3-5 Wiring of Solenoid Valve on Inlet for Valve in Parallel and Series

**MODEL: F71B/F71G/F67B/F67C/F67G/N75A/N75B**

**2) Liquid Level Controller Controls Inlet Pump (Two-phase motor) (Set b-01)**

Instruction: For the system using underground water or middle-tank supplying water, users can turn on and turn off the pump by operating the switch of liquid level controller and control valve. The wiring refers to Figure 3-6.

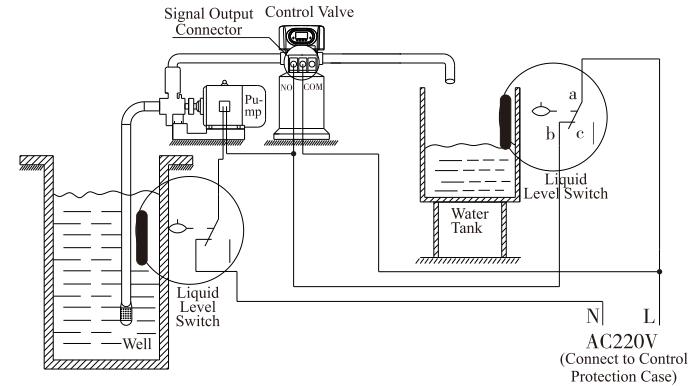

Figure 3-6 Wiring of Liquid Level Controller Controls 220V Inlet Pump

**Function:**

When valve is in service status, if water tank is short of water, pump starts working, but if water tank has enough water, the switch of liquid level controller is closed, so pump doesn't work.

When valve is in backwash cycle, inlet always has water no matter what is water condition in water tank. As Runxin valve no water passes outlet in regeneration cycle, it ensure no water fill into water tank.

A liquid switch at the top opening of well or in middle water tank in RO system protects pump from working without water in case of out of raw water.

**3) Liquid Level Controller in Water Tank Controls Inlet pump (Three-phase) (Set b-01)**

The principle is the same as for two-phase's, only change single-phase pump into three-phase motor, and use an AC contactor (Refer to Figure 3-7)

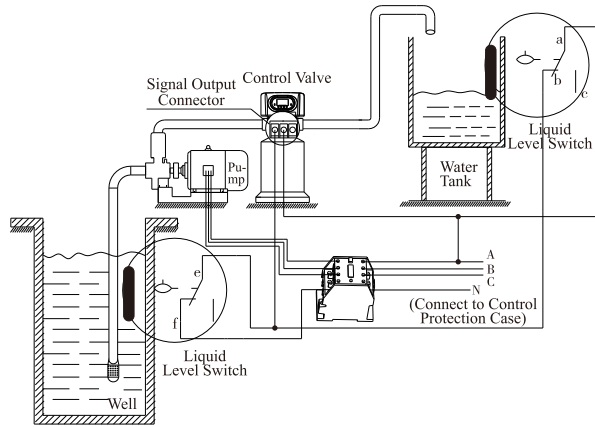

Figure 3-7 Wiring of Liquid Level Switch in Water Tank Controls 380V Inlet Pump

4) Control Inlet Booster Pump (Set b-01)

Instruction: If inlet water pressure is less than 0.15MPa, which makes rinsing or brine drawing difficult, a booster pump is suggested to be installed on inlet. Set control mode as b-01, when system in regeneration cycle, booster pump opens, the wiring refers to Figure 3-8. If the booster pump current is bigger than 5A, system need to install a contactor, the wiring refers to Figure 3-9.

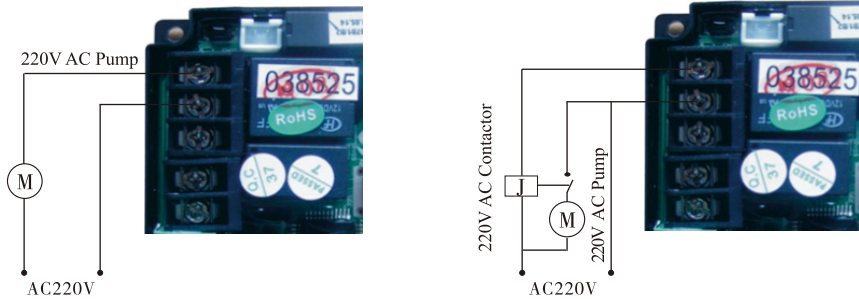

Figure 3-8 Wiring of Booster Pump on Inlet Figure 3-9 Wiring of Booster Pump on Inlet

**B. Interlock**

Instruction: In the parallel water treatment system, it ensures only one valve in rinsing status and (n-1) valves in service, that is, realizing the function of supplying water simultaneously and rinsing individually.

In the series water treatment system(Second grade Na<sup>+</sup> Exchanger or RO pre-treatment system), it ensures only one valve in rinsing status and there is/are water(s) in service. The wiring refers to Figure 3-10.

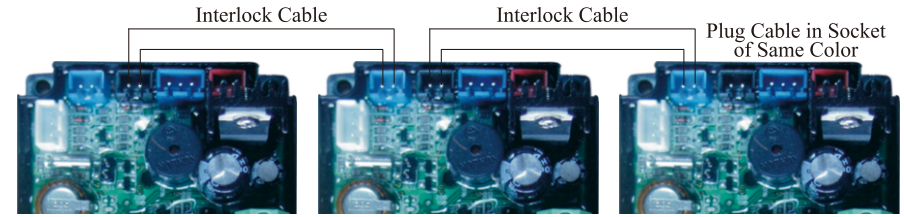

Figure 3-10 Network System Wiring with Interlock Cable

Use interlock cable to connect CN8 to CN7 on next valve in the loop.

One system with several valves, if interlock cable is disconnected, the system is divided into two individual system.

**C. Pressure Relief Connector**

Runxin valve will cut off feeding water to drain line when it switches in rinsing cycles. Thus in some water treatment system, e.g. Deep Well, one booster pump was installed on the inlet to increase the system water feeding pressure, this cut-off will cause pressure on inlet rinsing too fast to damage the valve. Pressure Relief Output can be used to avoid this problem. The wiring refers to Figure 3-11.

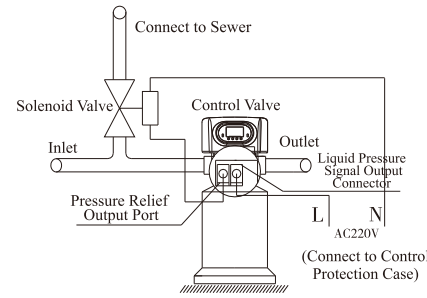

Figure 3-11 Wiring of Pressure Relief Connector

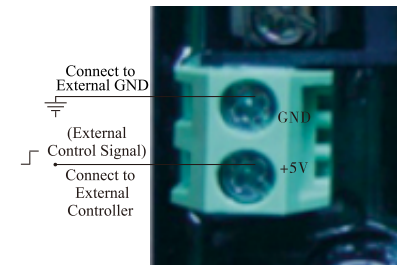

Figure 3-12 Wiring of Remote Handling Connector

**D. Remote Handling Connector**

When the valve is used to make pure water or other system that can be monitored online or connected to a PC, etc., when the conductivity or other parameters reach the set value or the PC sends a signal and needs system regeneration, it can be provide a signal to remote handling connector of main control board by the signal line, which can make the valve rinsing immediately. The connector receiving the signal is equivalent to pressing the manual button The wiring refers to Figure 3-12.

3.3. System Configuration and Flow Rate Curve

A. Product Configuration

Product configuration with tank, filter materials volume:

Tank Size	Volume of Filter Material	Carbon Filter		Sand Filter	
		Filtering Flow Rate	Backwash Flow Rate	Filtering Flow Rate	Backwash Flow Rate
mm	L	m <sup>3</sup> /h	m <sup>3</sup> /h	m <sup>3</sup> /h	m <sup>3</sup> /h
φ 180 × 1130	16	0.3	0.9	0.6	1.3
φ 205 × 1300	25	0.4	1.1	0.8	1.7
φ 255 × 1390	40	0.6	1.7	1.2	2.6
φ 300 × 1390	60	0.8	2.5	1.7	3.8
φ 355 × 1670	100	1.2	3.4	2.4	5.2
φ 400 × 1670	120	1.5	4.5	3.1	6.8
φ 450 × 1670	150	2	5.9	4.1	8.8
φ 500 × 1800	200	2.4	7	4.9	10.6
φ 600 × 1800	300	3.4	10	7	15.2

Note: The filtering flow rate of carbon filter is calculated based on the 12m/h operation rate; the backwash flow rate is calculated based on the 10L/(m<sup>2</sup>\*s) backwash intensity; the filtering flow rate of sand filter is calculated based on the 25m/h operation rate; the backwash flow rate is calculated based on the 15L/(m<sup>2</sup>\*s) backwash intensity.

B.Flow Rate Characteristic

1) Pressure-flow rate curve

F71

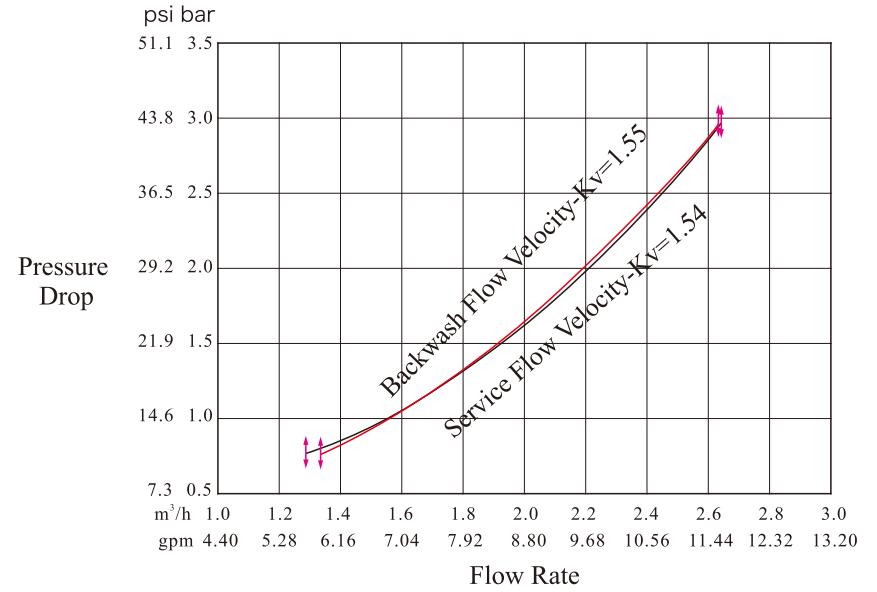

F67

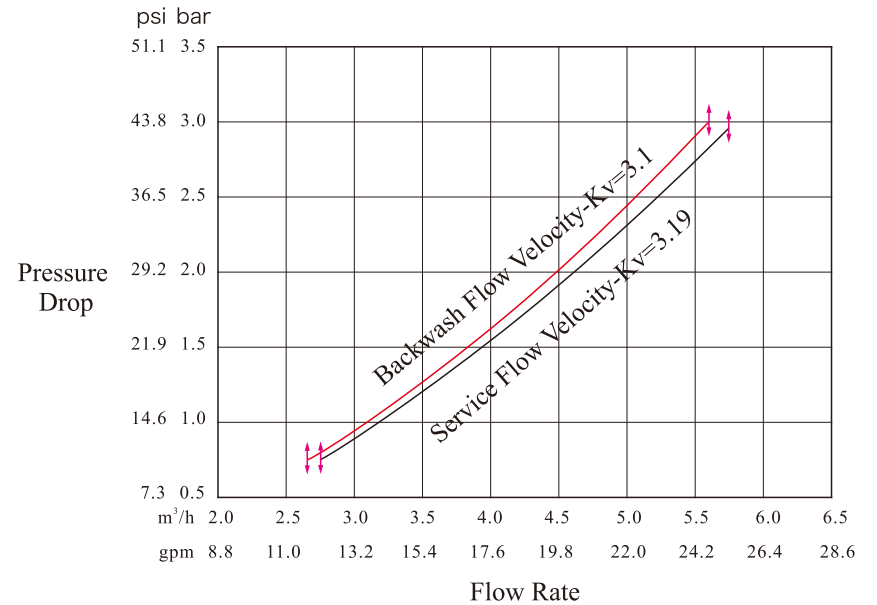

N75

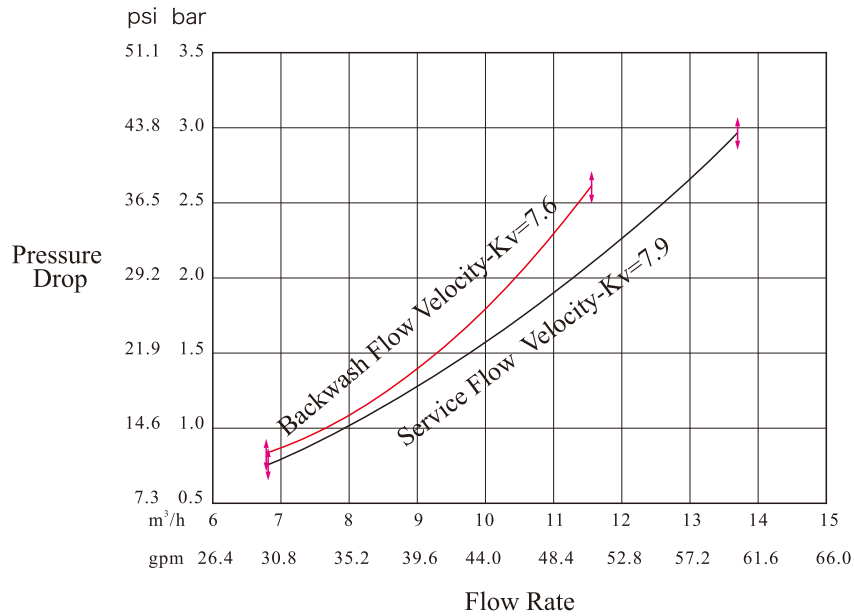

### 3.4. Parameter Enquiry and Setting

#### 3.4.1. Parameter Enquiry

When lights on, press and hold both and for 5 seconds to lift the button lock status; then press and lights on, enter to program display mode; press or to view each value according to below process. (Press exit and turn back to service status)

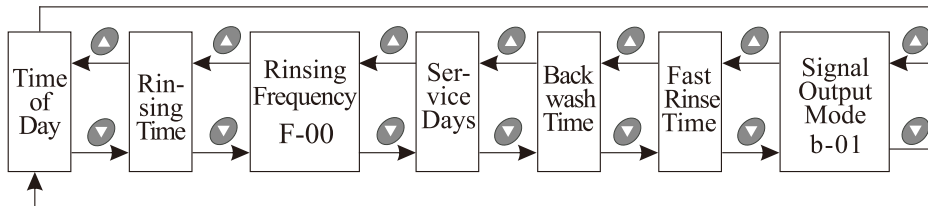











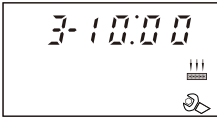

#### 3.4.2 Parameter Setting

In program enquiry mode, press and enter into program set mode. Press or to adjust the value.

### 3.4.3 The steps of parameter setting

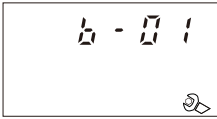

Items	Process steps	Symbol
Time of Day	When the Time of Day "12:12" continuously flashes, it reminds to reset: 1. Press  to enter into program display mode; both  and  symbol light on, ":" flashes; 2. Press , and enter into program set mode, both  and hour value flash, press  or  to adjust the hour value; 3. Press  again, both  and minute value flash, press  or  to adjust the minute value; 4. Press  and hear a sound "Di", then finish adjustment, press  to turn back.	
Rinsing Time	1. In the Rinsing Time program display mode, press  and enter into program set mode,  and 02 value flash; press  or  to adjust the hour value; 2. Press  again, both  and "00" flash, press  or  to adjust the minute value; 3. Press  and hear a sound "Di", then finish adjustment, press  to turn back.	
Rinsing Frequency	1. In the Rinsing Frequency display mode, it shows "F-00"; press  and enter into program set mode.  and 00 flash; 2. Press  or  to adjust the value; 3. Press  and hear a sound "Di" then finish adjustment, press  to turn back.	
Service Days	1. In the Service Days display mode, it shows  and "1-03"; press  and enter into program set mode.  and 03 flash; 2. Press  or  to adjust the value; 3. Press  and hear a sound "Di" then finish adjustment, press  to turn back.	
Back-wash Time	1. In the Backwash Time display mode, it shows  and "2-10:00"; press  and enter into program set mode.  and 10:00 flash; 2. Press  or  to adjust the value; 3. Press  and hear a sound "Di", then finish adjustment, press  to turn back.	



Fast Rinse Time	<p>1. In the Fast Rinse Time display mode, it shows  and "3-10:00"; press  and enter into program set mode.  and 10:00 flash;</p> <p>2. Press  or  to adjust the value;</p> <p>3. Press  and hear a sound "Di" then finish adjustment, press  to turn back.</p>	
Signal Output Mode	<p>1. In Signal Output Mode display mode, it shows b-01. Press  and enter into program set mode.  and 01 flash;</p> <p>2. Press  or  to adjust signal output mode;</p> <p>3. Press  and hear a sound "Di", then finish adjustment, press  to turn back.</p>	



### 3.5. Trial Running

After installing the multi-functional flow control valve on the tank with the connected pipes, as well as setting up the relevant parameter, please conduct the trial running as follows:

A. Close the inlet valve B & outlet valve C, and open the bypass valve A. After cleaning the foreign materials in the pipe, close the by-pass valve A. (As Figure 1-2 shows).

B. Press  and enter into the Backwash position; when  lights on, slowly open the inlet valve B to 1/4 position, making the water flows into the resin tank; you can hear the sound of air-out from the drain pipeline. After all air is out of pipeline, then open inlet valve B completely and clean the foreign materials in the tank until water from drain is clean. It will take 8~10 minutes to finish the whole process.

C. Press , turning the position from Backwash to Fast Rinse;  lights on and starts to fast rinse. It will take 10~15 minutes to finish the whole process.

D. After finishing fast rinse, take some outlet water for testing: if the water reaches the requirement, press  to finish the fast rinse; Then the control valve will turn to Service Status;  lights on and starts to running.

#### Illustration:

In the process of rinsing, the program will be finished automatically in accordance with the setting time; pressing the  button can end one step in advance and proceed to the next step.

#### Note:

● If water inflows too fast, the media in tank will be damaged. When water inflows slowly, there is a sound of air emptying from drain pipeline.

● After changing the filter materials, please empty air in the materials according to the above Step B.

● In the process of trial running, please check the water situation in all position, and ensure there is no filter materials leakage.

● The time for Backwash and Fast Rinse position can be set and executed according to the suggestions from the control valve suppliers.

### 3.6. Trouble-Shooting

#### A. Control Valve Fault

Problem	Cause	Correction
1. Filter fails to rinse.	<p>A. Electrical service to unit has been interrupted.</p> <p>B. Rinse time is set incorrect.</p> <p>C. Control valve is damage.</p>	<p>A. Assure permanent electrical service (check fuse, plug or switch).</p> <p>B. Reset the time.</p> <p>C. Check or replace the valve.</p>
2. Filter supplies raw water.	<p>A. Bypass ball valve is opened.</p> <p>B. Riser pipe leaks.</p> <p>C. Interval valve leaks.</p>	<p>A. Close the bypass ball valve.</p> <p>B. Make sure riser pipe and O-ring are not cracked.</p> <p>C. Check or change valve body.</p>
3. Water pressure is lost.	<p>A. Iron is massed in the water supply pipe.</p> <p>B. Iron is massed in the filter.</p>	<p>A. Clean the water supply pipe.</p> <p>B. Clean valve and add filter materials cleaning chemical, increase frequency of rinsing.</p>
4. Loss of filter materials through drain line.	<p>A. Air in the water system.</p> <p>B. The strength of backwash is too high.</p> <p>C. Strainer is broken.</p>	<p>A. Assure that the system is dry and has proper air eliminator control.</p> <p>B. Reduce the strength of backwash.</p> <p>C. Replace the strainer.</p>
5. Control valve cycles continuously.	<p>A. Wire of locating board breaks down.</p> <p>B. Control valve is damaged.</p> <p>C. Foreign material stuck the driving gear.</p>	<p>A. Check and connect wire of locating board.</p> <p>B. Replace control valve.</p> <p>C. Take out foreign material.</p>
6. Drain flows continuously.	<p>A. Internal valve leaks.</p> <p>B. Electricity fails to supply when the valve is in backwash or fast rinse position.</p>	<p>A. Check and repair valve body or replace it.</p> <p>B. Turn off bypass valve and restart when power on.</p>

B. Controller Fault

Problem	Cause	Correction
1. All indicators display on front panel.	A. Wire of display board and control board is damaged. B. Control board is damaged. C. Transformer is damaged. D. Electrical service is not stable.	A. Check and replace the wires. B. Replace control board. C. Check and replace transformer. D. Check and adjust electrical service.
2. No display on front panel.	A. Wire of display board and control board is damaged. B. Display board is damaged. C. Control board is damaged. D. Electricity is interrupted.	A. Check and replace wires. B. Replace display board. C. Replace control board. D. Check electricity.
3. E1 Flashes	A. Wire of display board and control board is damaged. B. Locating board is damaged. C. Mechanical driven is damaged. D. Control board is damaged. E. Wiring of motor with control board is damaged. F. Motor is damaged.	A. Replace wires. B. Replace locating board. C. Check and repair mechanical part. D. Replace control board. E. Replace wires. F. Replace motor.
4. E2 Flashes	A. Hall component on locating board is damaged. B. Wire of display board and control board is damaged. C. Control board is damaged.	A. Replace locating board. B. Replace wires. C. Replace control board.
5. E3 or E4 Flashes	A. Control board is damaged.	A. Replace control board.

3.7. Assembly & Parts

F71B1 (53502) Valve Body Assembly

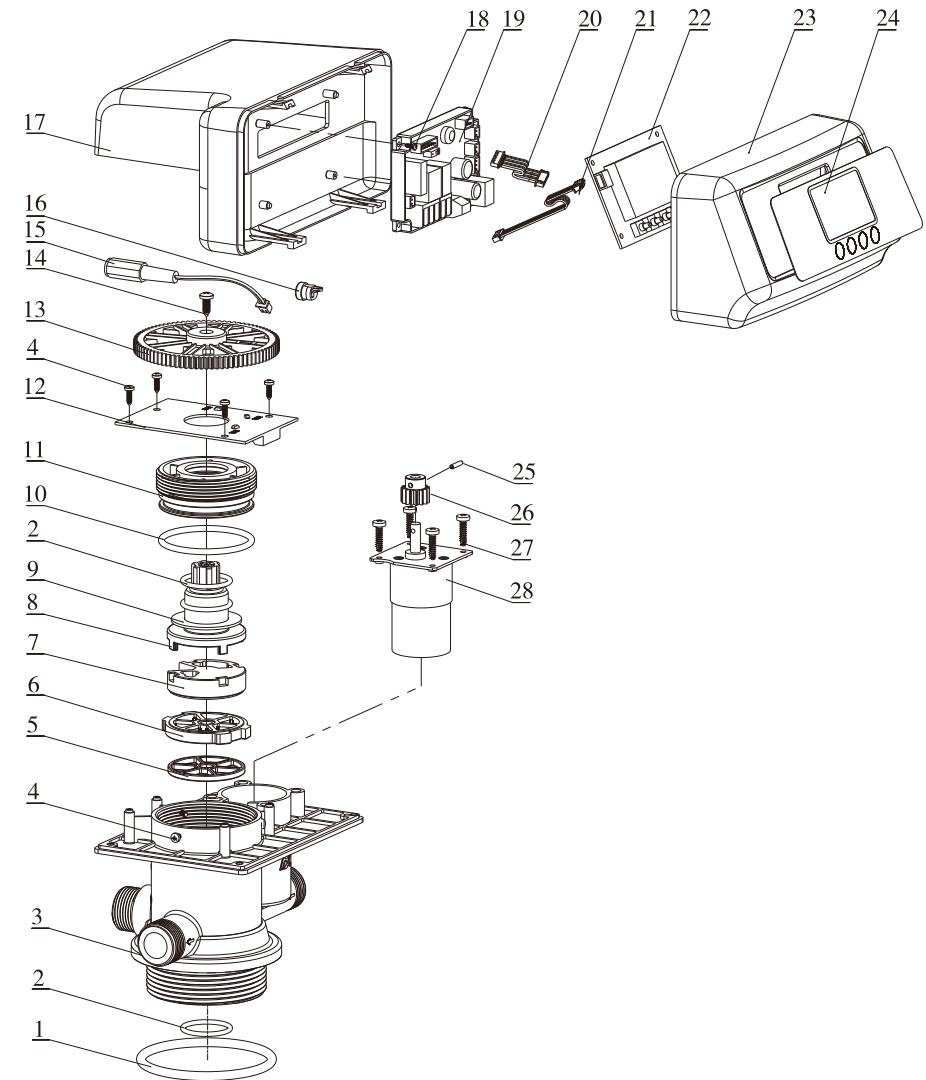



MODEL: F71B/F71G/F67B/F67C/F67G/N75A/N75B

F71B1 (53502) Valve Body Components

Item No.	Description	Part Number	Quantity	Item No.	Description	Part Number	Quantity
1	O-ring 73 × 5.3	8378143	1	15	Wire for Power	5513001	1
2	O-ring 25.8 × 2.65	8378078	3	16	Cable Clip	8126004	1
3	Valve Body (ABS+GF10)	5022160	1	17	Dust Cover	8005005	1
	Valve Body (PPO+GF20)	5022161		18	Screw, Cross ST2.2×6.5	8909004	2
4	Screw, Cross ST2.9×9.5	8909008	6	19	Control Board	6382003	1
5	Sealing Ring	8370038	1	20	Wire for Locating Board	5511001	1
6	Fixed Disk	8469018	1	21	Wire for Display Board	5512001	1
7	Moving Disk	8459019	1	22	Display Board	6381003	1
8	Shaft	8258009	1	23	Front Cover	8300004	1
9	Anti-friction Washer	8216010	1	24	Label	8865004	1
10	O-ring 50.39×3.53	8378107	1	25	Pin Φ2.5×12	8993003	1
11	Fitting Nut	8092007	1	26	Small Gear, Motor	8241010	1
12	Locating Board	6380009	1	27	Screw, Cross	8909044	4
13	Big Gear, Driven	5241005	1	28	Motor	6158006	1
14	Screw, Cross ST3.9×13	8909013	1				

MODEL: F71B/F71G/F67B/F67C/F67G/N75A/N75B

F71G1 (53502B) Valve Body Assembly

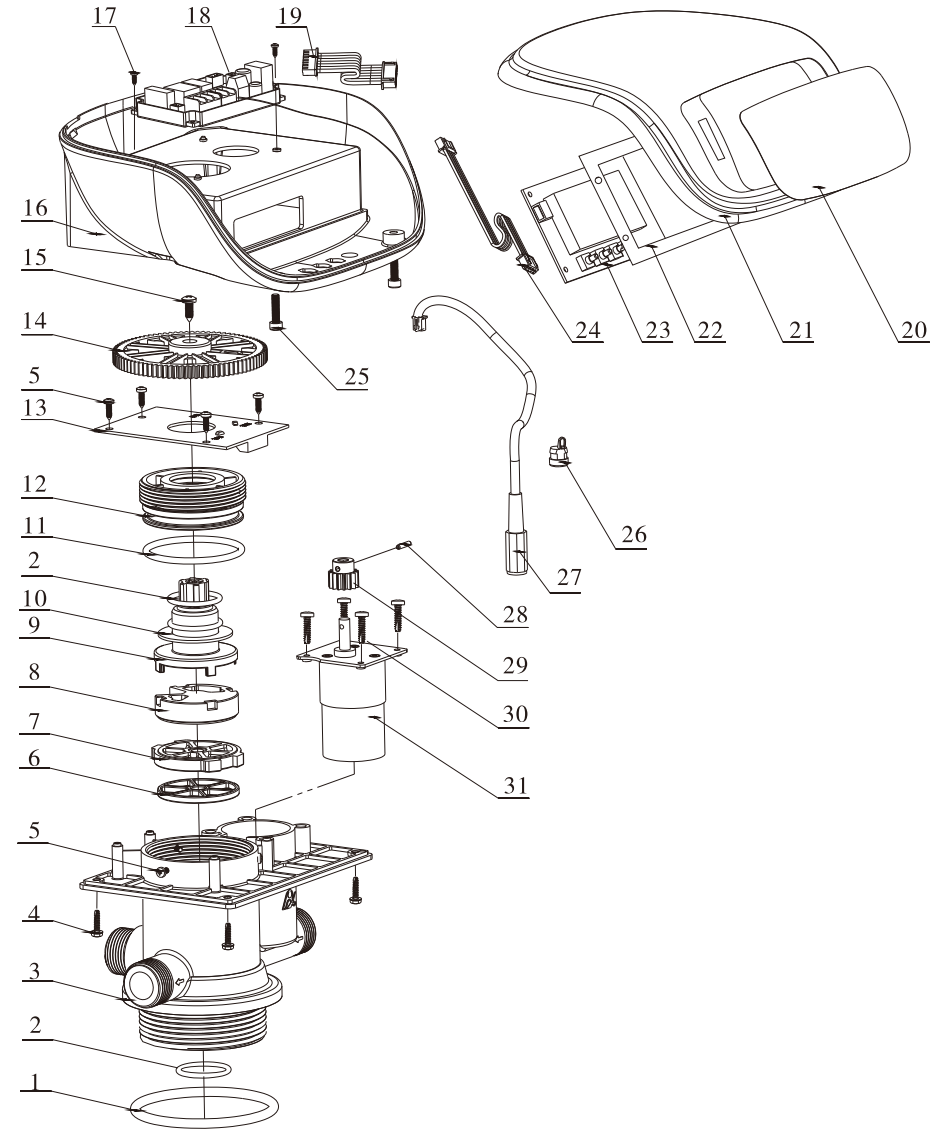

MODEL: F71B/F71G/F67B/F67C/F67G/N75A/N75B

F71G1 (53502B) Valve Body Components

Item No.	Description	Part Number	Quantity	Item No.	Description	Part Number	Quantity
1	O-ring 73 × 5.3	8378143	1	16	Dust Cover	8005020	1
2	O-ring 25.8 × 2.65	8378078	3	17	Screw, Cross ST2.2 × 6.5	8909004	2
3	Valve Body (ABS+GF10)	5022160	1	18	Control Board	6382003	1
	Valve Body (PPO+GF20)	5022161		19	Wire for Locating Board	5511001	1
4	Screw, Cross ST3.9 × 16	8909016	4	20	Label	8865021	1
5	Screw, Cross ST2.9 × 9.5	8909008	6	21	Front Cover	5300002	1
6	Sealing Ring	8370038	1	22	Toggle	8109028	1
7	Fixed Disk	8469018	1	23	Display Board	6381003	1
8	Moving Disk	8459019	1	24	Wire for Display Board	5512001	1
9	Shaft	8258009	1	25	Hexagon Socket Head Cap Screws M4 × 16	8902016	2
10	Anti-friction Washer	8216010	1	26	Cable Clip	8126004	1
11	O-ring 38.7 × 3.55	8378107	1	27	Wire for Power	5513001	1
12	Fitting Nut	8092007	1	28	Pin Φ2.5 × 12	8993003	1
13	Locating Board	6380009	1	29	Small Gear, Motor	8241010	1
14	Big Gear, Driven	5241005	1	30	Screw, Cross	8909044	4
15	Screw, Cross ST3.9 × 13	8909013	1	31	Motor	6158006	1

MODEL: F71B/F71G/F67B/F67C/F67G/N75A/N75B

F67B1 (53504S) Valve Body Assembly

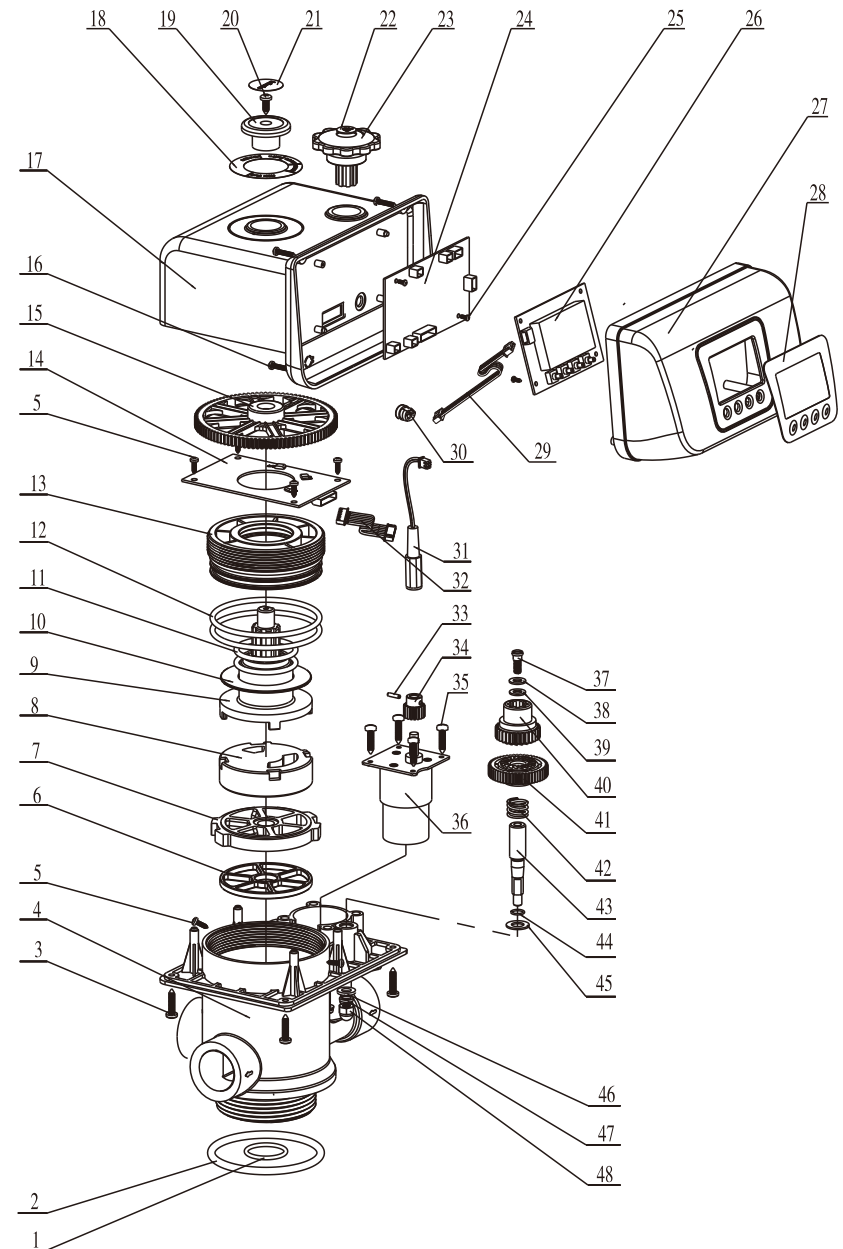

**MODEL: F71B/F71G/F67B/F67C/F67G/N75A/N75B**

**F67B1 (53504S) Valve Body Components**

Item No.	Description	Part Number	Quantity	Item No.	Description	Part Number	Quantity
1	O-ring 25.8×2.65	8378078	1	25	Screw, Cross ST2.2×6.5	8909004	4
2	O-ring 73×5.3	8378143	1	26	Display Board	6381003	1
3	Screw, Cross ST3.9×16	8909016	4	27	Front Cover	8300001	1
4	Valve Body (ABS+GF10)	5022188	1	28	Label	8865002	1
	Valve Body (PPO+GF20)	5022189		29	Wire for Display Board	5512001	1
5	Screw, Cross ST2.9×9.5	8909008	6	30	Cable Clip	8126004	1
6	Sealing Ring	8370027	1	31	Wire for Power	5513001	1
7	Fixed Disk	8469013	1	32	Wire for Locating Board	5511001	1
8	Moving Disk	8459014	1	33	Pin φ2.5×12	8993001	1
9	Shaft	8258001	1	34	Small Gear	8241004	1
10	Anti-friction Washer	8216004	1	35	Screw, Cross ST3.9×16	8909044	4
11	O-ring 38.7×3.55	8378184	2	36	Motor	6158016	1
12	O-ring 73×3.55	8378128	2	37	Screw	8906001	1
13	Fitting Nut	8092004	1	38	Gasket	8950004	1
14	Locating Board	6380004	1	39	Anti-friction Washer	8216005	1
15	Big Gear, Driven	5241001	1	40	Drive Gear	8243001	1
16	Screw, Cross ST2.9×16	8909010	4	41	Variable Gear	8243002	1
17	Dust Cover	8005001	1	42	Spring	8282001	1
18	Label	8869011	1	43	Connecting Rod	8040001	1
19	Pointer	8441001	1	44	Clip	8994001	1
20	Screw, Cross ST3.9×13	8909013	1	45	Collar	8950006	1
21	Symbol Label	8868004	1	46	Flat Gasket	8952007	1
22	Trademark	8860001	1	47	Spring Washer	8953001	1
23	Wheel Handle	8253001	1	48	Cap Nut M6	8949001	1
24	Control Board	6382003	1				

**MODEL: F71B/F71G/F67B/F67C/F67G/N75A/N75B**

**Note:**

**F67B1-A valve body components: Part No. for item 4 is "5022195".**

**F67B1-A/P valve body components: Part No. for item 4 is "5022196".**

**F67C1 (53504) Valve Body Assembly**

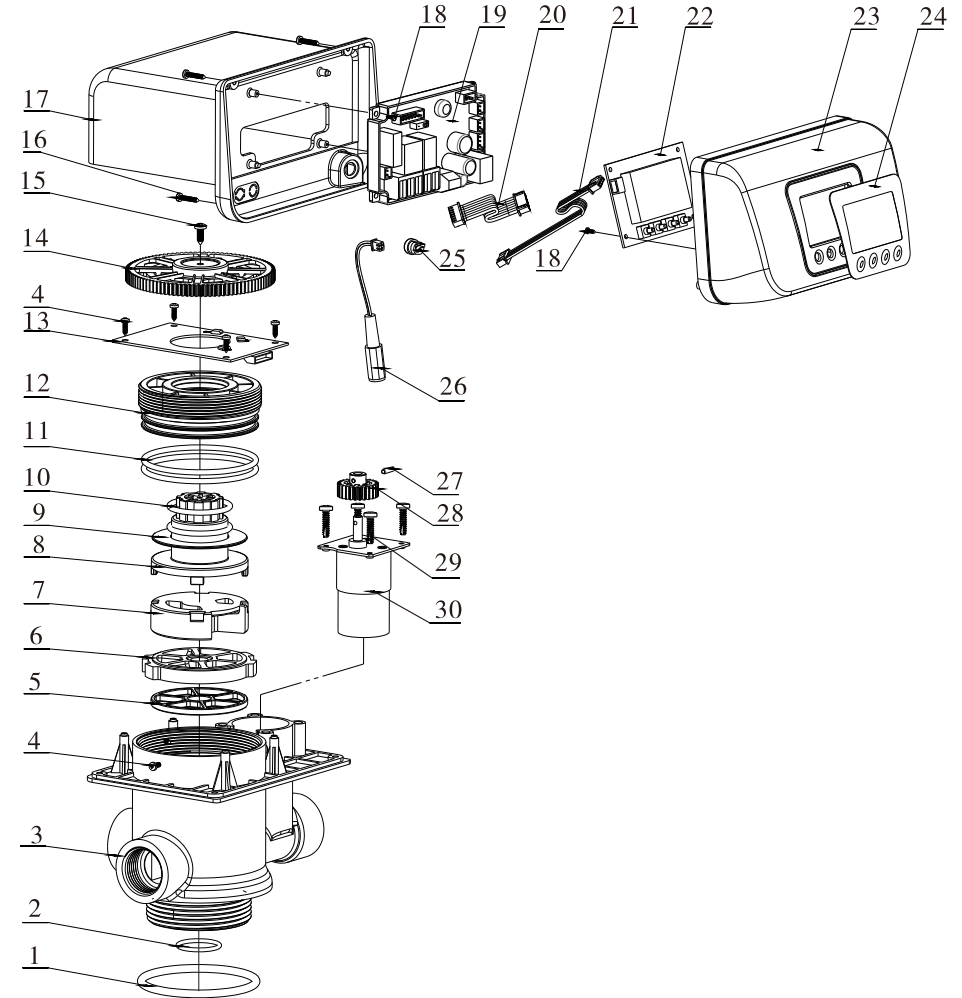

MODEL: F71B/F71G/F67B/F67C/F67G/N75A/N75B

F67C1 (53504) Valve Body Components

Item No.	Description	Part Number	Quantity	Item No.	Description	Part Number	Quantity
1	O-ring 73 × 5.3	8378143	1	16	Screw, Cross ST2.9 × 16	8909010	4
2	O-ring 25.8 × 2.65	8378078	1	17	Dust Cover	8005006	1
3	Valve Body (ABS+GF10)	5022162	1	18	Screw, Cross ST2.2 × 6.5	8909004	4
	Valve Body (PPO+GF20)	5022163		19	Control Board	6382003	1
4	Screw, Cross ST2.9 × 9.5	8909008	6	20	Wire for Locating Board	5511001	1
5	Sealing Ring	8370027	1	21	Wire for Display Board	5512001	1
6	Fixed Disk	8469013	1	22	Display Board	6381003	1
7	Moving Disk	8459014	1	23	Front Cover	8300001	1
8	Shaft	8258004	1	24	Label	8865002	1
9	Anti-friction Washer	8216004	1	25	Cable Clip	8126004	1
10	O-ring 38.7 × 3.55	8378184	2	26	Wire for Power	5513001	1
11	O-ring 73 × 3.55	8378128	2	27	Pin Φ2.5 × 12	8993003	1
12	Fitting Nut	8092004	1	28	Small Gear, Motor	8241003	1
13	Locating Board	6380004	1	29	Screw, Cross	8909044	4
14	Big Gear, Driven	5241002	1	30	Motor	6158021	1
15	Screw, Cross ST3.9 × 13	8909013	1				

MODEL: F71B/F71G/F67B/F67C/F67G/N75A/N75B

F67G1 (53504B) Valve Body Assembly

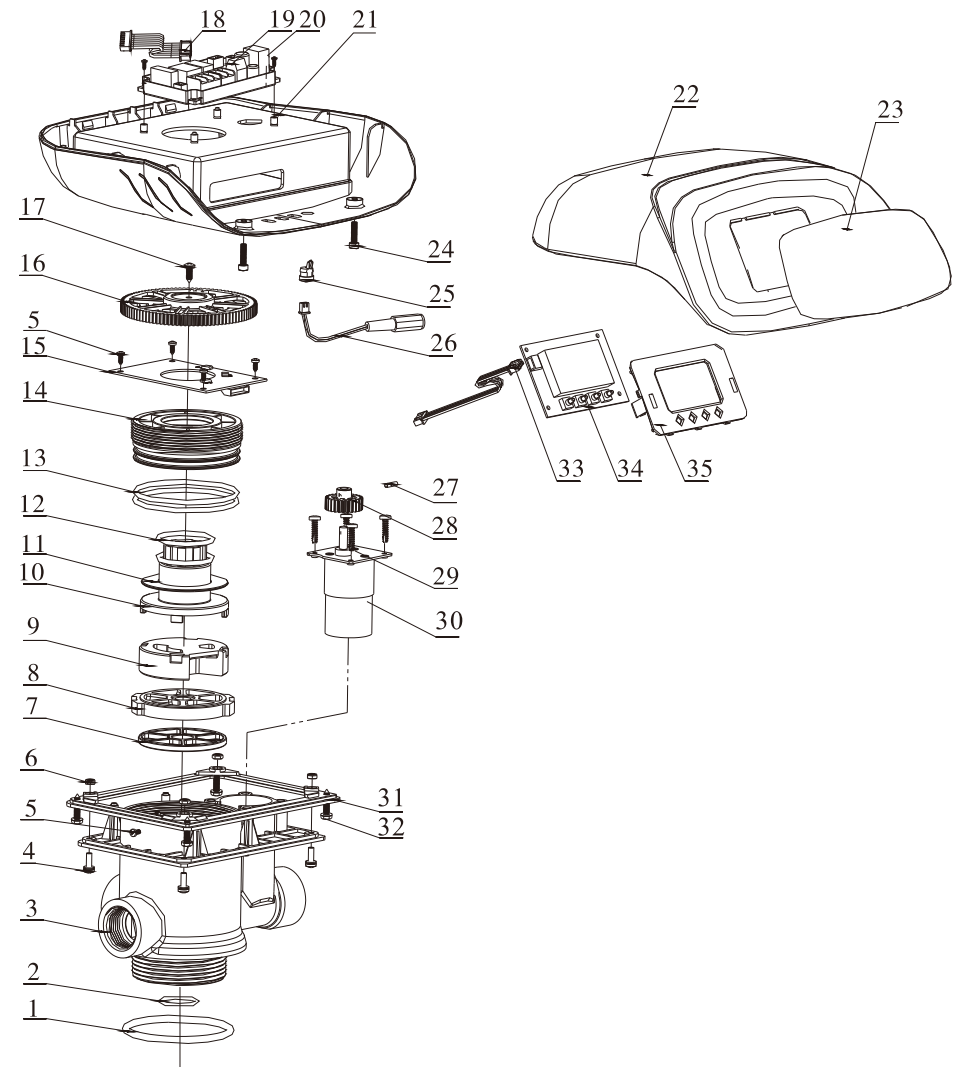

**MODEL: F71B/F71G/F67B/F67C/F67G/N75A/N75B**

**F67G1 (53504B) Valve Body Components**

Item No.	Description	Part Number	Quantity	Item No.	Description	Part Number	Quantity
1	O-ring 73 × 5.3	8378143	1	18	Wire for Locating Board	5511001	1
2	O-ring 25.8 × 2.65	8378078	1	19	Control Board	6382003	1
3	Valve Body (ABS+GF10)	5022162	1	20	Screw, Cross ST2.2 × 6.5	8909004	2
	Valve Body (PPO+GF20)	5022163		21	Dust Cover	8005019	1
4	Screw, Cross M4 × 14	8902005	4	22	Front Cover	5300001	1
5	Screw, Cross ST2.9 × 9.5	8909008	6	23	Label	8865020	1
6	Hexagonal Nut	8940002	4	24	Hexagon Socket Head Cap Screws M4 × 16	8902016	2
7	Sealing Ring	8370027	1	25	Cable Clip	8126004	1
8	Fixed Disk	8469013	1	26	Wire for Power	5513001	1
9	Moving Disk	8459014	1	27	Pin Φ2.5 × 12	8993003	1
10	Shaft	8258004	1	28	Small Gear, Motor	8241003	1
11	Anti-friction Washer	8216004	1	29	Screw, Cross	8909044	4
12	O-ring 38.7 × 3.55	8378184	2	30	Motor	6158021	1
13	O-ring 73 × 3.55	8378128	2	31	Connecting Plate	8152013	1
14	Fitting Nut	8092004	1	32	Screw, Cross ST3.9 × 16	8909016	4
15	Locating Board	6380004	1	33	Wire for Display Board	5512001	4
16	Big Gear, Driven	5241002	1	34	Display Board	6381003	1
17	Screw, Cross ST3.9 × 13	8909013	1	35	Fixer	8109027	1

**MODEL: F71B/F71G/F67B/F67C/F67G/N75A/N75B**

**N75A1 (53510) Valve Body Assembly:**

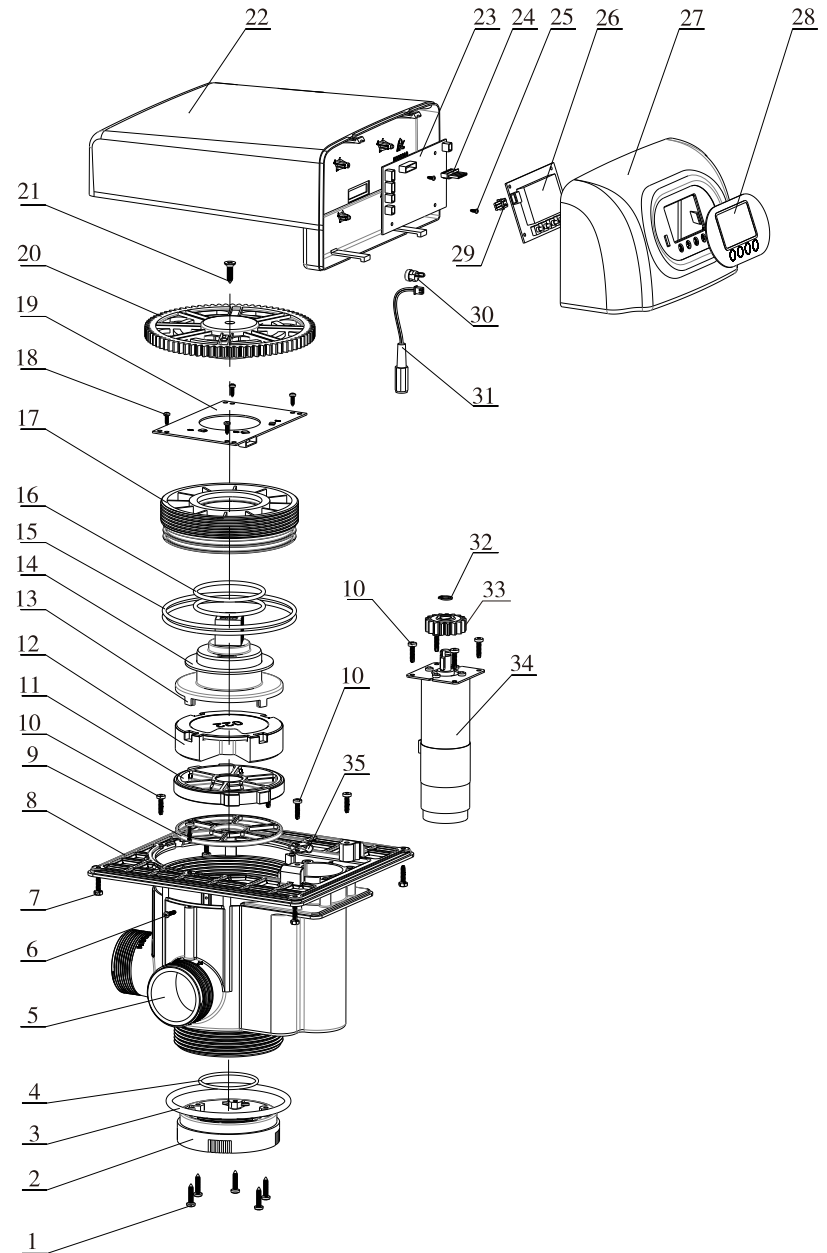

MODEL: F71B/F71G/F67B/F67C/F67G/N75A/N75B

N75A1 (53510) Valve Body Components

Item No.	Description	Part Number	Quantity	Item No.	Description	Part Number	Quantity
1	Screw, Cross ST3.9 × 19	8909003	5	18	Screw, Cross ST2.9 × 9.5	8909008	4
2	Connector	8458018	1	19	Locating Board	6380016	1
3	O-ring 104.6 × 5.7	8378146	1	20	Big Gear, Driven	5241014	1
4	O-ring 50.47 × 2.62	8378308	1	21	Screw, Cross ST4.8 × 19	8909018	1
5	Valve Body (ABS+GF20)	5022072	1	22	Dust Cover	8005010	1
	Valve Body (PPO+GF10)	5022178			23	Control Board	6382027
6	Screw, Cross ST2.9 × 13	8909023	2	24	Wire for Locating Board	5511002	1
7	Screw, Cross ST3.9 × 16	8909016	4	25	Screw, Cross ST2.2 × 6.5	8909004	2
8	Connecting Plate	8152007	1	26	Display Board	6381003	1
9	Sealing Ring	8370014	1	27	Front Cover	8300017	1
10	Screw, Cross ST3.9 × 16	8909044	9	28	Label	8865016	1
11	Fixed Disk	8469009	1	29	Wire for Display Board	5512001	1
12	Moving Disk	8459022	1	30	Cable Clip	8126004	1
13	Shaft	8258005	1	31	Wire for Power	5513001	1
14	Anti-friction Washer	8216006	1	32	Pin	8994009	1
15	O-ring 117.6 × 3.55	8378133	2	33	Small Gear, Motor	8241008	1
16	O-ring 59.92 × 3.53	8378110	2	34	Motor	6158037	3
17	Fitting Nut	8092032	1	35	Wire Clip	8126002	1

MODEL: F71B/F71G/F67B/F67C/F67G/N75A/N75B

N75B1 (53510B) Valve Body Assembly

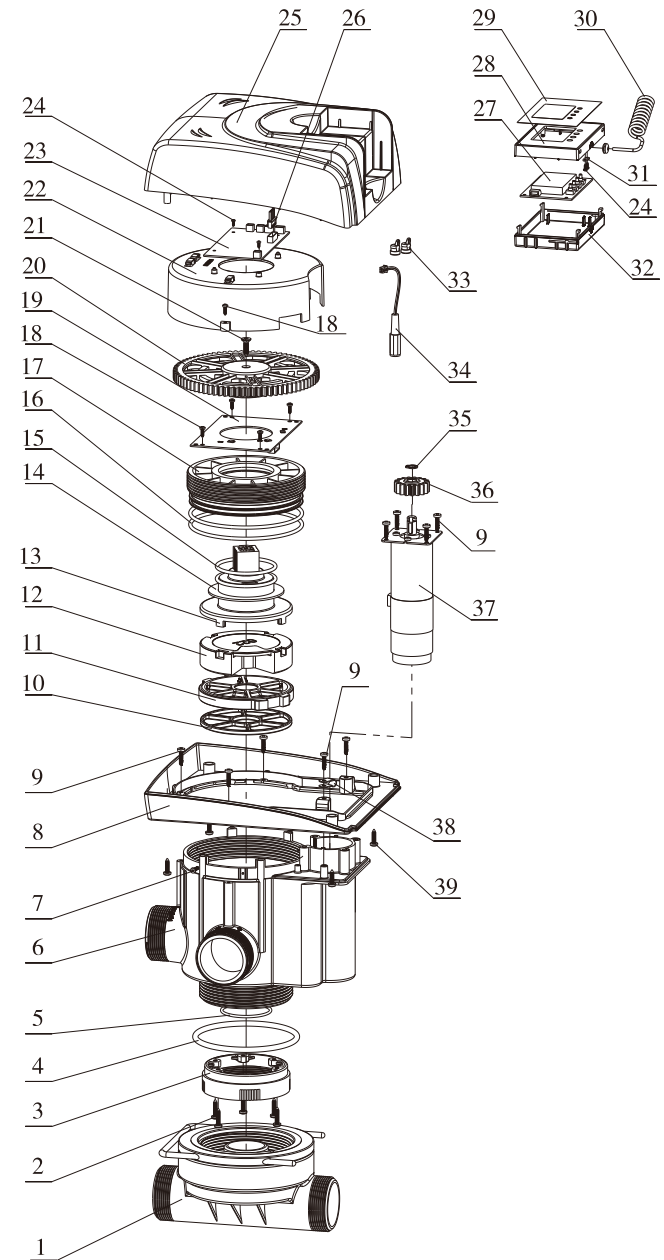

MODEL: F71B/F71G/F67B/F67C/F67G/N75A/N75B

N75B1 (53510B) Valve Body Components

Item No.	Description	Part Number	Quantity	Item No.	Description	Part Number	Quantity
1	Side-mounted Connector	5458002	1	20	Big Gear, Driven	5241014	1
2	Screw, Cross ST3.9 × 19	8909003	5	21	Screw, Cross ST4.8 × 19	8909018	1
3	Connector	8458018	1	22	Fixing Seat	8109004	1
4	O-ring 104.6 × 5.7	8378146	1	23	Control Board	6382027	1
5	O-ring 50.47 × 2.62	8378308	1	24	Screw, Cross ST2.2 × 6.5	8909004	4
6	Valve Body (ABS+GF20)	5022072	1	25	Dust Cover	8005023	1
	Valve Body (PPO+GF10)	5022178		26	Wire for Locating Board	5511002	1
7	Screw, Cross ST2.9 × 13	8909023	2	27	Display Board	6381003	1
8	Connecting Plate	8152012	1	28	Front Cover	8300025	1
9	Screw, Cross ST3.9 × 16	8909044	9	29	Label	8865023	1
10	Sealing Ring	8370014	1	30	Spring Wire	5517001	1
11	Fixed Disk	8469009	1	31	Cord	8126001	1
12	Moving Disk	8459022	1	32	Cover	8315016	1
13	Shaft	8258005	1	33	Cable Clip	8126004	2
14	Anti-friction Washer	8216006	1	34	Wire for Power	5513001	1
15	O-ring 59.92 × 3.53	8378110	2	35	Pin	8994009	1
16	O-ring 117.6 × 3.55	8378133	1	36	Small Gear, Motor	8241008	1
17	Fitting Nut	8092032	1	37	Motor	6158037	1
18	Screw, Cross ST2.2 × 9.5	8909008	6	38	Cable Clip	8126002	1
19	Locating Board	6380016	1	39	Screw, Cross ST3.9 × 16	8909030	4

MODEL: F71B/F71G/F67B/F67C/F67G/N75A/N75B

5458002 Side-mounted Connector Body Assembly

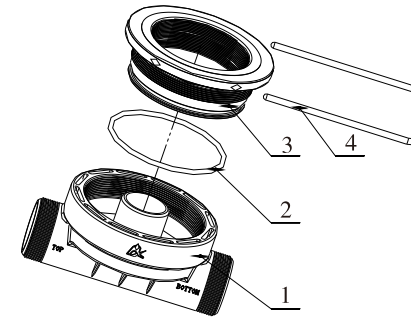

5458002 Side-mounted Connector Body Components

Item No.	Description	Part Number	Quantity	Item No.	Description	Part Number	Quantity
1	Connection	8458037	1	3	Connector	8457017	1
2	O-ring 110 × 4.5	8378140	1	4	Steel Fork	8271003	1

### 4. Warranty Card

Dear client:

This warranty card is the guarantee proof of multi-functional flow control valve. It is kept by client self. You could get the after-sales services from the supplier which is appointed by Runxin manufacturer. Please keep it properly. It couldn't be retrieved if lost.

It couldn't be repaired free of charge under the below conditions:

1. Guarantee period expired. (One year)
2. Damage resulting from using, maintenance, and keeping that are not in accordance with the instruction.
3. Damage resulting from repairing not by the appointed maintenance personnel.
4. Content in guarantee proof is unconfirmed with the label on the real good or be altered.
5. Damage resulting from force majeure.

Product Name	 Multi-functional Flow Control Valve for Water Treatment Systems			
Model		Code of Valve Body		
Purchase Company Name		Tel/Cel.		
Problem				
Solution				
Date of Repairing		Date of Accomplishment		Maintenance Man Signature

When product needs warranty service, please fill in the below content and send this card together with the product to the appointed suppliers or Runxin company.

End-user Company Name		Tel/Cel.		
Purchase Company Name		Tel/Cel.		
Model		Code of Valve Body		
Tank Size $\phi$	×	Filter Material	Kg	Water Source: Ground-water <input type="checkbox"/> Tap Water <input type="checkbox"/>
Service Time	D or h	Backwash Time	min	Fast Rinse Time min
Problem Description				