



China Patent No.ZL201720650460.8

Multi-functional Flow Control Valve for Water Treatment Systems

56603/56603M (Old Model No.: F67N/F67M)



WENZHOU RUNXIN MANUFACTURING MACHINE CO.,LTD

ADD: NO.169, RUNXIN ROAD, SHANFU TOWN, WENZHOU, ZHEJIANG, CHINA.

TEL.:0086-577-88630038, 88576512, 85956057 FAX:0086-577-88633258

E-MAIL: sales@run-xin.com <http://www.run-xin.com>

Rev.A.2207

User Manual



Please read this manual in details
before using the valve and keep it properly
in order to consult in the future.

0WRX.466.707

3.3. System Configuration and Flow Rate Curve

A. Product configuration

1) Product configuration with tank, filter materials volume and flow rate

Tank Size	Volume of Filter Materials	Activated Carbon Filter		Sand Filter	
		Filter Flow Rate	Backwash Flow Rate	Filter Flow Rate	Backwash Flow Rate
mm	L	m ³ /h	m ³ /h	m ³ /h	m ³ /h
φ 180 × 1130	16	0.3	0.9	0.6	1.3
φ 205 × 1300	25	0.4	1.1	0.8	1.7
φ 255 × 1390	40	0.6	1.7	1.2	2.6
φ 300 × 1390	60	0.8	2.5	1.7	3.8
φ 355 × 1650	100	1.2	3.4	2.4	5.2
φ 400 × 1650	120	1.5	4.5	3.1	6.8

Note: The filter flow rate of activated carbon filter is calculated based on the 12m/h service flow velocity; the backwash flow rate is calculated based on the 10L/(m²*s) backwash intensity; the filter flow rate of sand filter is calculated based on the 25m/h service flow velocity; the backwash flow rate is calculated based on the 15L/(m²*s) backwash intensity.

B. Flow rate characteristic

1). Pressure-flow rate curve

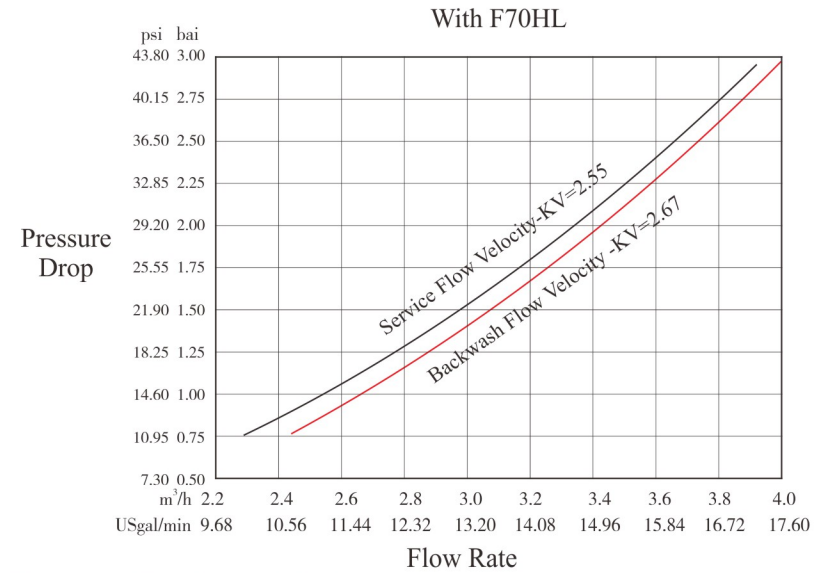
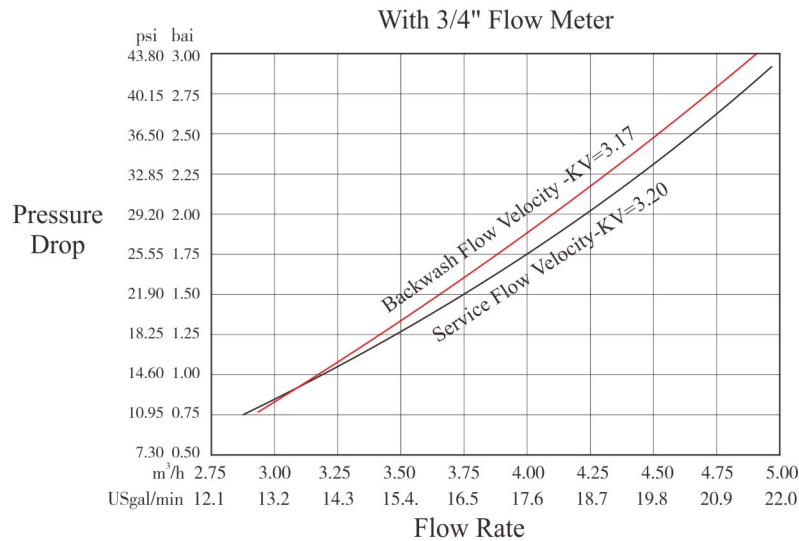

3.4. Parameter Enquiry and Setting

A. Enter background mode



























When the screen shows 2-A interface (see P12) within 6 seconds after connecting power, enter background mode by pressing and holding and for more than 2 seconds. The screen shows as Figure 3-A1, 3-A2 and 3-A3.



































B. Background parameter setting items

Several items can be set in the background mode, such as mode, valve model, water capacity, flow rate unit, rinsing frequency, backwash time, fast rinse time, media service days, set media volume, adsorption ratio, interval rinsing days and signal output mode.

» Set Mode- Filter Set Valve Model-F67N Set Water Capacity-10:00 m ³ Set Flow Rate Unit-m ³ ↓	» Rinsing Frequency-F-00↑ Set Backwash Time-02 min. Set F.R. Time-03 min. Media Service Day-360 Days ↓	» Set Media Volume-22L Adsorption Ratio-70g/L Interval Rinsing D. -30 Days Signal Output Mode-b-01 ↑	
3-A1	3-A2	3-A3	
Set Mode <input checked="" type="radio"/> Filter <input type="radio"/> Softener	Set Valve Model <input type="radio"/> F67D <input type="radio"/> F71D <input checked="" type="radio"/> F67N	<input type="radio"/> F67N-A	Set Water Capacity 10.00m ³
3-B	3-C1	3-C2	3-D

Set Flow Rate Unit <input type="radio"/> gal <input type="radio"/> L <input checked="" type="radio"/> m ³	Rinsing Frequency F-00	Set Backwash Time 02 min.	Set F.R. Time 03 min.
3-E	3-F	3-G	3-H
Media Sevice Day 360 Days	Set Media Volume 22L	Adsorption Ratio 70g/L	Interval Rinsing D. 30 Days
3-I	3-J	3-K	3-L
Signal Output Mode <input checked="" type="radio"/> b-01 <input type="radio"/> b-02			
3-M			

- ①When the screen shows as 3-A1, choose “Set Mode”, press , show as the figure 3-B. Press  and  to choose different mode. Press , it will save value and return to 3-A1; Press , it will return to 3-A1 without saving value.
- ②When the screen shows as 3-A1, choose “Set Valve Model”, press , show as the figure 3-C1. Press  and  to choose different valve model. Press , it will save value and return to 3-A1; Press , it will return to 3-A1 without saving value.
- ③When the screen shows as 3-A1, choose “Set Water Capacity”, press , show as the figure 3-D. Press  and  to choose different water treatment capacity. Press , it will save value and return to 3-A1; Press , it will return to 3-A1 without saving value.
- ④When the screen shows as 3-A1, choose “Set Flow Rate Unit”, press , show as the figure 3-E. Press  and  to choose different flow rate unit. Press , it will save value and return to 3-A1; Press , it will return to 3-A1 without saving value.
- ⑤When the screen shows as 3-A2, choose “Rinsing Frequency”(F-00 means service one time, fast rinse and backwash 1 time; F-01 means service one time, fast rinse and backwash 2 times; And so on.) Press , show as the figure 3-F. Users can press  and  to choose different number. Press , it will save value and return to 3-A2; Press , it will return to 3-A2 without saving value.
- ⑥When the screen shows as 3-A2, choose “Set Backwash Time”, press , show as the

- figure 3-G. Press  and  to choose different backwash time. Press , it will save value and return to 3-A2; Press , it will return to 3-A2 without saving value.
- ⑦When the screen shows as 3-A2, choose “Set F.R. Time”, press , show as the figure 3-H. Press  and  to choose different fast rinse time. Press , it will save value and return to 3-A2; Press , it will return to 3-A2 without saving value.
 - ⑧When the screen shows as 3-A2, choose “Media Sevice Day”, press , show as the figure 3-I. Press  and  to choose different media sevice day. Press , it will save value and return to 3-A2; Press , it will return to 3-A2 without saving value.
 - ⑨When the screen shows as 3-A3, choose “Set Media Volume”, press , show as the figure 3-J. Press  and  to choose different media volume. Press , it will save value and return to 3-A3; Press , it will return to 3-A3 without saving value.
 - ⑩When the screen shows as 3-A3, choose “Adsorption Ratio”, press , show as the figure 3-K. Press  and  to choose different adsorption ratio. Press , it will save value and return to 3-A3; Press , it will return to 3-A3 without saving value.
 - ⑪When the screen shows as 3-A3, choose “Interval Rinsing D.”, press , show as the figure 3-L. Press  and  to choose different interval rinsing days. Press , it will save value and return to 3-A3; Press , it will return to 3-A3 without saving value.
 - ⑫When the screen shows as 3-A3, choose “Signal Output Mode” (refer to P5), press , show as the figure 3-M. Press  and  to choose different signal output mode. Press , it will save value and return to 3-A3; Press , it will return to 3-A3 without saving value.

3.5.Trial Running

After installing the multi-functional flow control valve on the tank with the connected pipes, as well as setting up the relevant parameters, please conduct the trail running as follows:

A. Close the inlet valve B and outlet valve C, and open the bypass valve A. After cleaning the impurity in the pipe, close the bypass valve A. (As P8 Figure 1-D shows).

B. Press  and turn the status to the backwash; slowly open the inlet valve B to 1/4 position, making the water flows into the resin tank; you can hear the sound of air-out from the drain pipeline. After all air is out of pipeline, then open inlet valve B completely and clean the filter materials in the tank until the outlet water is clean. It will take 8~10 minutes to finish the whole process.

C. The program will conduct automatically or press , turning the status from backwash to fast rinse.

If the valve is first put into use, it needs backwash and fast rinse for several times to wash

remaining filter materials until the drain water is clean.



D. The program will conduct automatically or press  , turning the status to service status, and filter water by turning on valve C and turning off valve A. Then turn on sample valve D or other outlet faucets to examine the quality of outlet water, if there is black water, it indicates the system needs backwash and fast rinse again.

Illustration:

In the process of rinsing, the program will be finished automatically in accordance with the setting time; pressing the  button can end one step in advance and proceed to the next step.

Note:

- **If water inflows too fast, the media in tank will be damaged. When water inflows slowly, there is a sound of air emptying from drain pipeline.**
- **After changing the filter materials, please empty air in the materials according to the above step B.**
- **In the process of trial running, please check the water situation in all status, ensuring there is no filter materials leakage.**
- **The time for backwash and fast rinse status can be set and executed according to the suggestions from the control valve suppliers.**

3.6.Trouble-Shooting

A.Control valve fault

Problem	Cause	Correction
1.Under abnormal condition, it is usually on closing status.	A. The leakage sensor damaged. B. Under non-leakage circumstances, the absorbent cotton of leakage sensor absorbs water to expand to shut off water.	A. Change the leakage sensor. B. Replace a new absorbent cotton.
2. Under abnormal condition, the current flow rate displays 0.	A. Probe wire is not inserted into the flow meter socket or inserted in a wrong place. B. Turbine is not put into flow meter. C. Foreign materials or filter materials plug turbine.	A. Insert the probe wire into flow meter socket. B. Put turbine into flow meter. C. Remove foreign materials or filter materials.
3.Filter fails to rinse.	A.Electrical service to unit has been interrupted. B. Rinse time is set incorrect. C. Control valve damaged.	A. Assure permanent electrical service (Check fuse, plug, switch and so on). B. Reset the time. C. Check or replace the valve.

4.Filter supplies raw water.	A. Riser pipe leaks. B. Interval valve leaks.	A. Make sure riser pipe and O-ring are not cracked. B. Check and repair valve body or replace it.
5.Water pressure lost.	A. Iron scale in the water supply pipe. B. Iron scale accumulated in the filter.	A. Clean the water supply pipe. B. Clean valve and add filter materials cleaning chemical, increase frequency of rinsing.
6. Filter materials discharged through drain pipe.	A. Air in the water system. B. The strength of backwash is too high. C. Strainer is broken.	A. Assure the system is dry and has proper air eliminator control. B. Reduce the strength of backwash. C. Replace the strainer.
7.Control valve cycle continuously.	A. Locating signal wire breakdown. B. Controller damaged. C. Foreign material stuck the driving gear.	A. Check and connect locating signal wire. B. Replace controller. C. Take out foreign material.
8.Drain flows continuously.	A. Internal valve leaks. B. Power off when in backwash or fast rinse	A. Check and repair valve body or replace it. B. Turn on bypass valve for water supply, close the inlet of valve and restart when electricity supply.

B.Controller fault

Problem	Cause	Correction
1.WIFI doesn't match well.	A. Install wrong APP. B. Users don't match the valve with cell phone in the right way. C. Wireless router breakdown.	A. Android users install Android APP; Iphone users install Iphone APP. B. Please refer to instructions for configuration of cell phone and valve. C.Replace the wireless router.
2.Messy code on display board.	A. Wire of display board with control board damaged. B. Control board damaged. C. Transformer got wet or damaged. D. Electrical service not stable.	A. Replace the wire. B. Replace control board. C. Check and replace transformer. D. Check and adjust electrical service.
3.No display on display board.	A. Wire of display board with control board damaged. B. Display board damaged. C. Control board damaged. D. Electricity is interrupted.	A. Replace the wire. B. Replace display board. C. Replace control board. D. Check electricity.

4.E1 Flash	A. Wire of locating board with control board damaged. B. Locating board damaged. C. Mechanical driven damaged. D. Control board damaged. E. Wire of motor with control board damaged F. Motor damaged.	A. Replace the wire. B. Replace locating board. C. Check and repair mechanical part. D. Replace control board. E. Replace the wire. F. Replace motor.
5.E2 Flash	A. Hall component on locating board damaged. B. Wire of locating board with control board damaged. C. Control board damaged.	A. Replace locating board. B. Replace the wire. C. Replace control board.
6.E3 or E4 Flash	A. Control board damaged.	A. Replace control board.
7.Under abnormal condition, it is usually on closing status.	A. The leakage sensor breaks down. B. Set value of continuous water time is too small. C. Set value of peak flow rate for close is too small.	A. Replace leakage sensor. B. Adjust continuous water time or set it as 0 to close this function. C. Adjust peak flow rate or set it as 0 to close this function.

3.7. Assembly & Parts

Flow meter connector and animated connector components

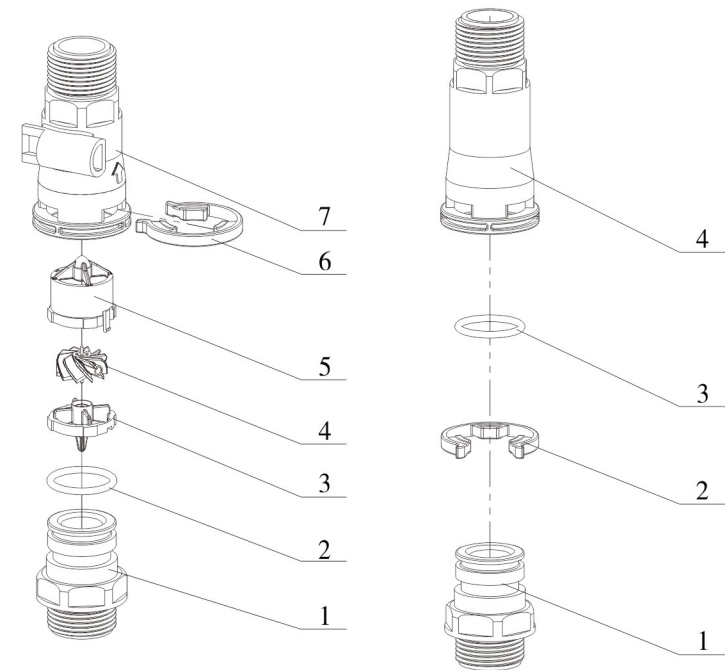

5447020 Flow Meter			
Item No.	Description	Part No.	Quantity
1	Connector	8458014	1
2	O-ring 21.89 × 2.62	8378064	1
3	Impeller Supporter	5115023	1
4	Turbine	5436013	1
5	Impeller Supporter	5115024	1
6	Clip	8270005	1
7	Shell	8002006	1

5457003 Animated Connector			
Item No.	Description	Part No.	Quantity
1	Connector	8458014	1
2	Clip	8270005	1
3	O-ring 21.89 × 2.62	8378064	1
4	Connector	8458039	1

Control Valve Mechanism Assembly

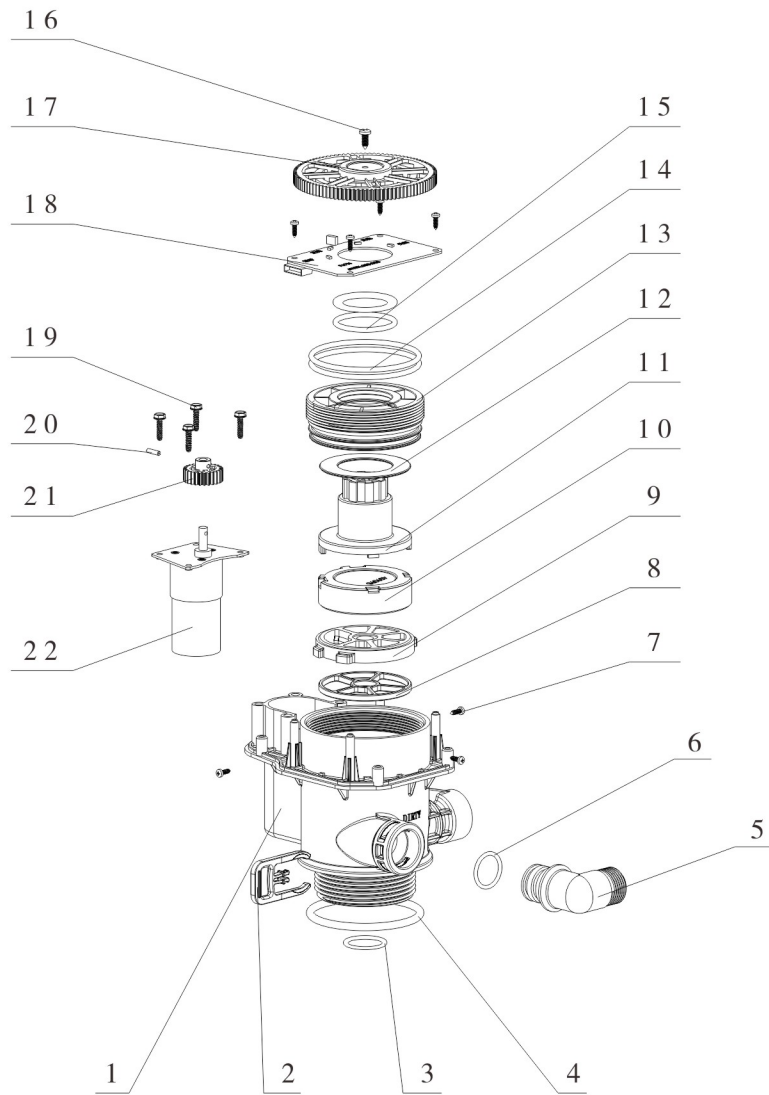

Control Valve Mechanism Components

Item No.	Description	Part No.	Quantity
1	Valve Body	5022144	1
2	Clip	8270008	1
3	O-ring $\phi 25.8 \times 2.65$	8378175	1
4	O-ring $\phi 73 \times 5.3$	8378160	1
5	Elbow Connector	8457035	1
6	O-ring $\phi 21.89 \times 2.62$	8378064	1
7	Screw, Cross ST2.9 $\times 9.5$	8909008	7
8	Seal Ring	8370131	1
9	Fixed Disk	8469100	1
10	Moving Disk	8459098	1
11	Shaft	8258004	1
12	Anti-friction Washer	8216004	1
13	Fitting Nut	8092004	1
14	O-ring $\phi 73 \times 3.55$	8378128	2
15	O-ring $\phi 38.7 \times 3.55$	8378184	2
16	Screw, Cross ST4 $\times 12$	8909013	1
17	Big Gear, Driven	5241002	1
18	Locating Board	6380058	1
19	Screw, Cross ST3.9 $\times 16$	8909016	4
20	Pin $\phi 2.5 \times 12$	8993003	1
21	Small Gear, Motor	8241003	1
22	Motor	6158073	1

F67N/M Valve Body Assembly

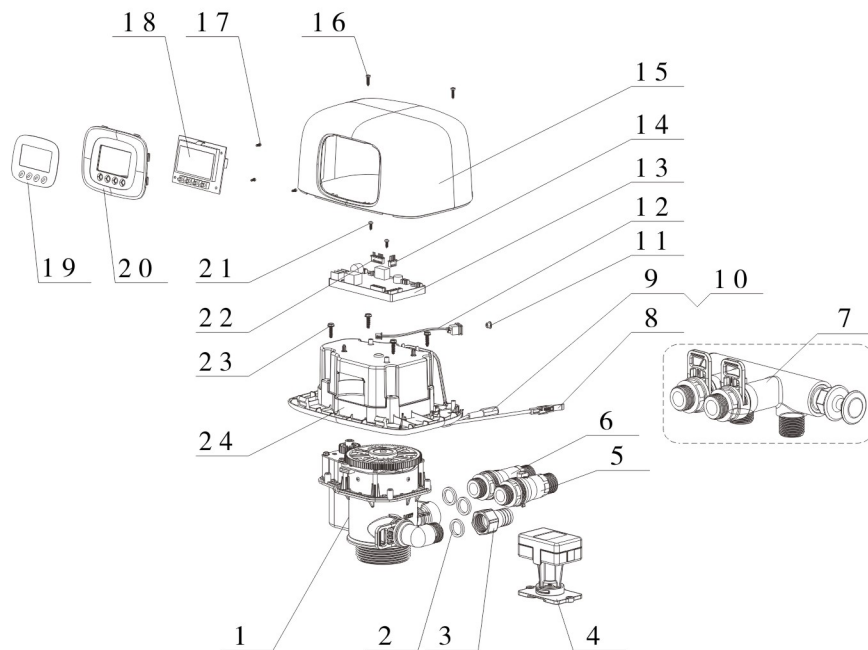
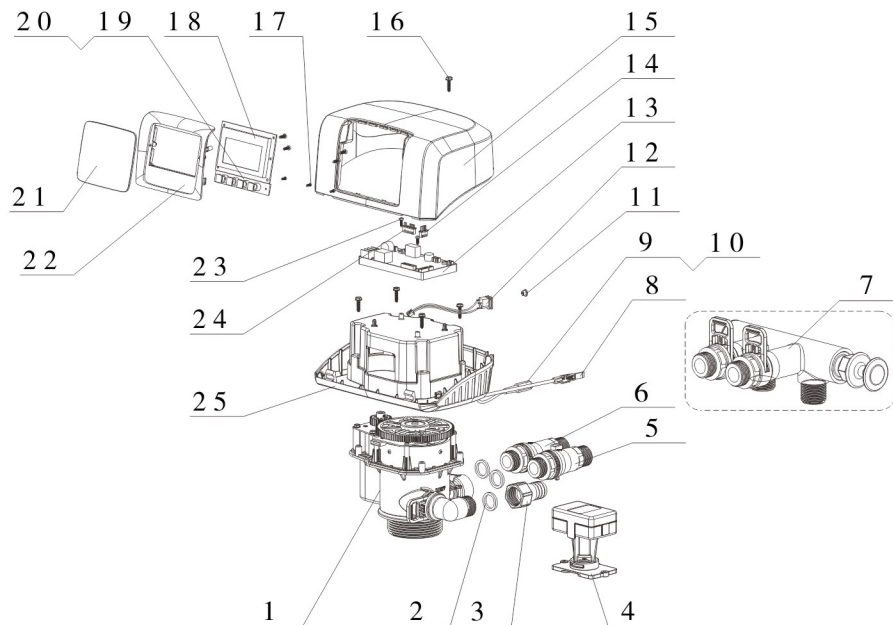

F67N/M Valve Body Components

F67N				F67M			
Item No.	Description	Part No.	Quantity	Item No.	Description	Part No.	Quantity
1	Contol Valve Mechanism Components	6794203	1	1	Contol Valve Mechanism Components	6794203	1
2	Seal Ring $\phi 24 \times \phi 18 \times 3$	8371019	3	2	Seal Ring $\phi 24 \times \phi 18 \times 3$	8371019	3
3	Drain Connector	8458151	1	3	Drain Connector	8458151	1
4	Leakage Sensor	2976255	1	4	Leakage Sensor	2976255	1
5*	Flow Meter	5447020	1	5*	Flow Meter	5447020	1
6*	Animated Connector	5457003	1	6*	Animated Connector	5457003	1
7*	F70HL Bypass Valve	2974116	1	7*	F70HL Bypass Valve	2974116	1
8	Probe Wire	6386014	1	8	Probe Wire	6386014	1
9	Wire for Power	5513003	1	9	Wire for Power	5513003	1
10	Cable Clip	8126004	2	10	Cable Clip	8126004	2
11	Plug	8323045	1	11	Plug	8323045	1
12	Wire for Leakage Sensor	5513039	1	12	Wire for Leakage Sensor	5513039	1
13	Control Board	6382144	1	13	Control Board	6382144	1
14	Wire of Display Board	5512002	1	14	Wire of Display Board	5512002	1
15	Dust Cover	8005085	1	15	Dust Cover	8005093	1
16	Screw, Cross ST3.9 $\times 16$	8909016	5	16	Screw, Cross ST2.9 $\times 13$	8909023	2
17	Screw, Cross ST2.2 $\times 6.5$	8909004	3	17	Screw, Cross ST2.2 $\times 6.5$	8909004	3
18	Big Display Board	6381031	1	18	Display Board	6381006	1
19	Button for Display Board	6381032	1	19	Label	8865178	1
20	Wire for Display Board	5517016	1	20	Toggle	8109135	1
21	Control Panel	5321078	1	21	Screw, Cross ST2.9 $\times 9.5$	8909008	2
22	Toggle	8109124	1	22	Wire for Locating Board	5511030	1
23	Screw, Cross ST2.9 $\times 9.5$	8909008	6	23	Screw, Cross ST3.9 $\times 16$	8909016	4
24	Wire for Locating Board	5511030	1	24	Bottom Cover	8315134	1
25	Bottom Cover	8315122	1				

Note: Item No.5 flow meter and No.6 animated connector as a fitting group, and item No.7 bypass valve are optional, it means each valve only has one of them.

4. Warranty Card

Dear client:

This warranty card is the guarantee proof of Runxin brand multi-functional flow control valve. It is kept by client self. You could get the after-sales services from the supplier which is appointed by Runxin manufacturer. Please keep it properly. It couldn't be retrieved if lost.

It couldn't be repaired free of charge under the below conditions:

1. Guarantee period expired. (One year)
2. Damage resulting from using, maintenance, and keeping that are not in accordance with the instruction.
3. Damage resulting from repairing not by the appointed maintenance personnel.
4. Content in guarantee proof is unconfirmed with the label on the real good or be altered.
5. Damage resulting from force majeure.

Product Name	 Multi-functional Flow Control Valve for Water Treatment Systems	
Model	Code of Valve Body	
Purchase Company Name	Tel/Cel.	
Problem		
Solution		
Date of Repairing	Date of Accomplishment	Maintenance Man Signature

When product needs warranty service, please contact with your direct supplier firstly, after got permission, then fill in the below content and send this card together with the product to the appointed suppliers or Runxin company.

End-user Company Name		Tel/Cel.	
Purchase Company Name		Tel/Cel.	
Model	Code of Valve Body		
Tank size $\phi \times$	Filter Material	Kg	Water Source: Ground-water <input type="checkbox"/> Tap Water <input type="checkbox"/>
Water Treatment Capacity m^3	Backwash Time	min	Fast Rinse Time
Problem Description			

Before the valve put into use, please fill in the below content so as to help us to refer in the future.

Filter System Configuration

Tank Size: Dia. _____ mm; Height _____ mm;

Refilled Filter Materials _____ L;

Granularity of Filter Materials _____ mm;

Control Valve Model _____; Number _____;

Pressure of Inlet Water _____ MPa;

Turbidity of Inlet Water _____ FTU;

Water Source: Ground-water ; Filtered Ground-water ;

Tap Water ; Other _____.

Parameter Set

Parameter	Unit	Factory Default	Actual Value
Time of Day	h:m	Time of Day	
Rinsing Time	h:m	02:00	
Raw Water Chlorine Content	mg/L	1.0	
Continuous Water Time	min.	00	
Peak Flow Rate for Close	m ³ /h	00	
Water Capacity	m ³	10.00	
Flow Rate Unit	/	m ³	
Rinsing Frequency	/	F-00	
Backwash Time	min.	2	
Fast Rinse Time	min.	3	
Media Service Day	D.	360	
Media Volume	L	22	
Chlorine Adsorption Ratio	g/L	70	
Interval Rinsing Days	D.	30	
Output Mode	/	b-01	

Catalogue

Notice ----- 3

1.Product Overview ----- 4

1.1.Main Application & Applicability----- 4

1.2.Product Characteristics ----- 4

1.3.Service Condition ----- 5

1.4.Product Structure and Technical Parameters ----- 6

1.5.Installation (Take F67N with 3/4" flow meter as an example)----- 7

2.Basic Setting & Usage ----- 10

2.1.The Function of PC Board----- 10

2.2.Basic Setting & Usage ----- 11

3.Applications ----- 15

3.1.Flow Chart ----- 15

3.2.The Function and Connection of PC Board ----- 15

3.3.System Configuration and Flow Rate Curve ----- 16

3.4.Parameter Enquiry and Setting ----- 17

3.5.Trial Running ----- 19

3.6.Trouble-Shooting ----- 20

3.7.Assembly & Parts ----- 23

4.Warranty Card ----- 28

Notice

- To ensure normal operation of the valve, please consult with professional installation or repairing personnel before use it.
- If there are any of pipeline engineering and electric works, there must be finished by professional at the time of installation.
- Do not use the control valve with the water that is unsafe or unknown quality.
- Test water periodically to verify that system is performing satisfactorily.
- Do not put the valve near the heat sources or surroundings with high humidity, corrosive, intense magnetic field or intense vibrations environment. And do not leave it outside.
- Please use this product under the water temperature between 5~50℃ water pressure 0.15~0.6MPa. Failure to use this product under such conditions voids the warranty.
- If the water pressure exceeds 0.6MPa, a pressure reducing valve must be installed before the water inlet. While, if the water pressure is under 0.15MPa, a booster pump must be installed before the water inlet.
- PPR pipes, corrugated pipes, or UPVC pipes are recommended for pipe installation and aluminum-plastic pipes should be avoided.
- Do not let children touch or play, because careless operations may cause the procedure changed.
- When the attached cables or transformer of this product are damaged, they must be changed to the one that is from our factory.

1. Product Overview

1.1. Main Application & Applicability

Used for intelligent control in filtering water treatment systems.

Be suitable for residential filtering system.

1.2. Product Characteristics

☞ Simple structure and reliable sealing

It adopts hermetic head faces with high degree pottery and corrosion resistance for opening and closing. It combines with Service, Close, Backwash, and Fast Rinse.

☞ Manual function

Realize rinsing immediately by pressing “” at any time.

☞ Long outage indicator

If outage overrides 3 days, it will always display the time indicator to remind people to reset new time of day. As shown in figure 1-A:

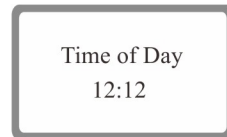



Figure 1-A

☞ LCD Screen display

It is easier to understand by adopting word to description valve working positions.

Users can choose Chinese, English or other languages to display interface: reconnect power, press and hold buttons “” and “” for 2 seconds to enter language selection interface.

☞ Leakage protection function

If the leakage sensor detects there is leakage during service, backwash or fast rinse status, the control valve will turn to close status automatically.

During the service status, if the actual continuous water time is longer than the set value, the control valve will turn to close status automatically. This function is useless if the continuous water time is set 0.

During the service status, if the actual flow rate exceeds the set value, the control valve will turn to close status automatically. This function is useless if the peak flow rate for close is set 0.

☞ Filter media replacement reminder function

After a long time of use, the adsorption capacity of the filter media has decreased. When the set days is exceeded or a certain water consumption is reached, the system will display the filter media maintenance interface to remind the user to maintain and replace the filter media.

☞ Closing function

During the service status, if the control valve is unlocked, press and hold “” for 5



seconds, it will turn to close status, shut off water to maintain or repair of the subsequent pipeline. Under close status and unlock condition, press and hold “” for 5 seconds, it will turn to service status automatically.

☞ Signal output (provide passive signal to control water pump)

Set the output mode as b-01, refer to the Figure on P15, when the valve is at non-service status, NO is connected with COM; when the valve is at service status, NO is unconnected with COM.

Set the output mode as b-02, refer to the Figure on P15, when the motor rotates, NO is connected with COM; if it is at working status, NO is unconnected with COM.

☞ Buttons lock

No operations to buttons on the controller within 1 minute, button lock indicator lights on which represents buttons are locked. Before operation, press and hold the “” and “” buttons for 5 seconds to unlock. This function can avoid incorrect operation.

☞ WIFI control function

Download and install correct APP by scanning QR code. Cell phone should be matched with control valve. Then users can remotely control and check the control valve by the phone.

☞ Foreground and Background Mode

Foreground mode is suitable for users, it is only used for setting parameters such as time of day, rinsing time, chlorine content, continuous water time and peak flow rate for close etc. Background mode can set regeneration time etc. (Refer to P18 for specific setting methods)

1.3. Service Condition

Filter valve should be used under the below conditions:

Item		Requirement
Working conditions	Working pressure	0.15MPa~0.6MPa
	Inlet water temperature	5°C~50°C
Working environment	Environment temperature	4°C~50°C
	Relative humidity	≤95%(25°C)
	Electrical facility	AC100~240V/50~60Hz
Inlet water quality	Water turbidity	Filter < 20FTU

● When the water turbidity exceeds the conditions, the impurity in the inlet water should be coagulated and precipitated firstly.

1.4.Product Structure and Technical Parameters

A.Dimension (The appearance is just for reference. It is subjected to the real product.)

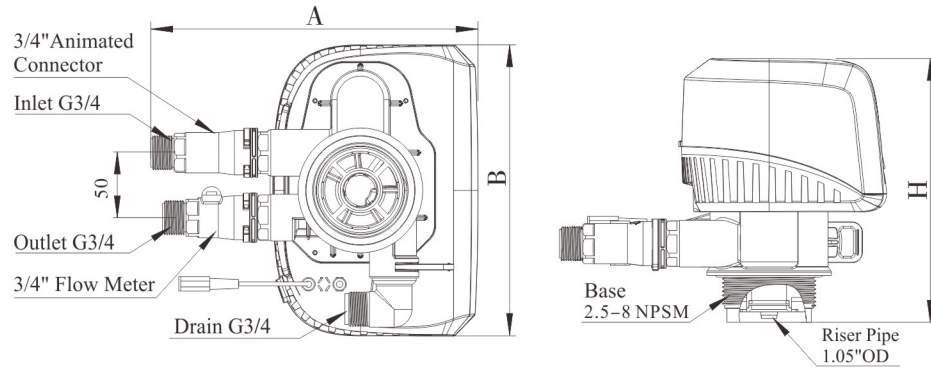

F67N with 3/4" Flow Meter

Model	A(mm) max	B(mm) max	H(mm) max	Flow Rate m ³ /h @0.1MPa Pressure Drop
F67N with 3/4" Flow Meter	252	224	193	3.0
F67M with 3/4" Flow Meter	254	224	195	3.0

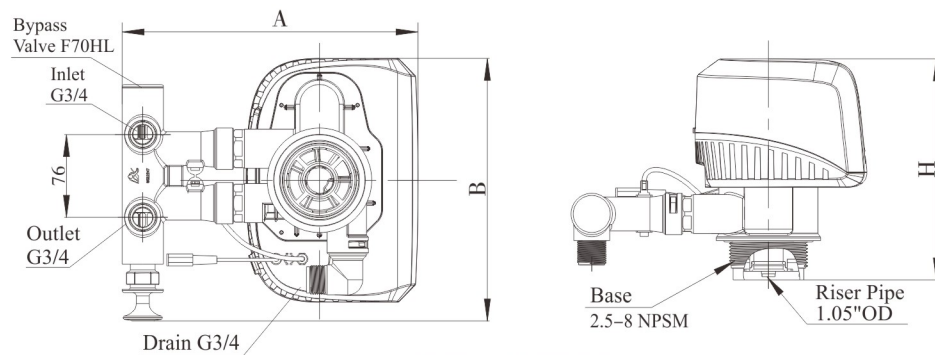

F67N with F70HL

Model	A(mm)max	B(mm)max	H(mm)max	Flow Rate m ³ /h @0.1MPa Pressure Drop
F67N with F70HL	272	241	193	2.5
F67M with F70HL	274	243	195	2.5

1.5.Installation (Take F67N with 3/4 inch flow meter as an example)

A.Installation notice

Before installation, read all those instructions completely. Then obtain all materials and tools needed for installation.

The installation of product, pipes and circuits should be accomplished by professional to ensure the product can operate normally.

Perform installation according to the relevant pipeline regulations and the specifications of Water Inlet, Water Outlet, and Drain Outlet.

B.Device location

- ①.The control valve should be located closely to drain.
- ②.Ensure the unit is installed in enough space for operating and maintenance.
- ③.The unit should be kept away from the heater, and exposed outdoor. Sunshine or rain will cause the system damage.
- ④.Please avoid installing the system in circumstance of acid/alkaline, magnetic or strong vibration circumstance, because above factors will cause the system disorder.
- ⑤.Do not install the filter, drain pipeline or overflow pipe in circumstance where temperature may drop below 4℃ or above 50℃.
- ⑥.Install the system in the place where with the minimum loss in case of water leaking.

C.Pipeline connection

①Install control valve

a.As the Figure1-B shows, select the 26.7mm riser pipe, glue the riser pipe to the bottom strainer and put it into the bottom of tank, cut off the exceeding pipe out of tank top opening and make external rounding.

b.Fill filter materials to the tank, and the height is accordance with the design code.

c. Install the top strainer to the valve.

d. Through the top strainer, insert the riser pipe into control valve and screw tight control valve.

Note:

- The length of riser pipe should be no lower 5mm than tank top opening height, and its top end should be rounded to avoid damaging of O-ring inside the valve.
- Avoid filling floccules substance together with filter materials to the tank. Avoid filter materials entering the riser pipe in case of locking turbine, which will cause the flow rate to display incorrectly.
- Avoid O-ring inside control valve falling out while rotating it on the tank.

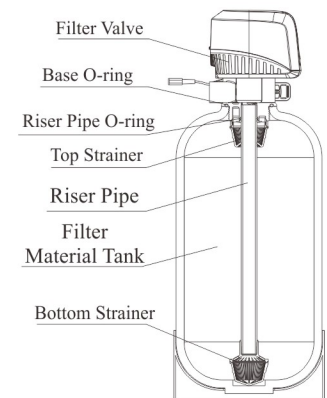

Figure 1-B

② Install animated connector

As Figure 1-C shows, put the washer in the inlet, and screw the animated connector into the inlet.

③ Install flow meter

As Figure 1-C shows, put the washer in the outlet and screw the flow meter into the outlet, then insert the probe into the flow meter.

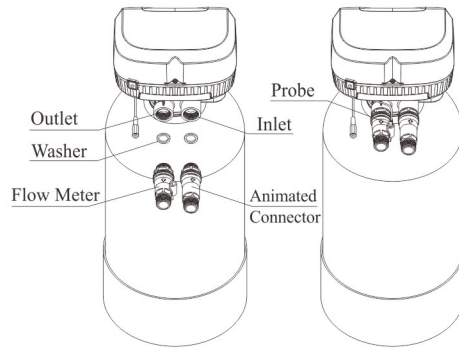

Figure 1-C

④ Pipeline connection

a. As the Figure 1-D shows, install a pressure gauge in water inlet.

b. Install valve A, valve B, valve C and valve D in the inlet, outlet and middle of the pipeline. The valve D is sampling valve.

The valve D is sampling valve.

c. Inlet pipeline should be in parallel with outlet pipeline. Support inlet and outlet pipeline with fixed holder.

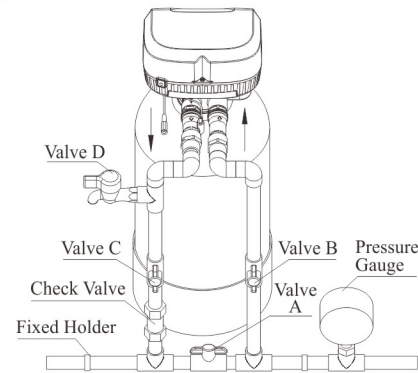

Figure 1-D

Note:

● If making a soldered copper installation, do all sweat soldering before connecting pipes to the valve. Torch heat will damage plastic parts.

● When turning threaded pipe fitting onto plastic fitting, do not use excessive force to make threads misaligned or broken valve.

⑤ Install drain pipeline

a. As the Figure 1-E shows, insert the flexible drain pipeline into the drain connector, and fixed with clamp.

b. Put the washer into drain connector.

c. Screw the drain connector together with elbow connector.

d. Insert the elbow connector into valve body and fixed with clip.

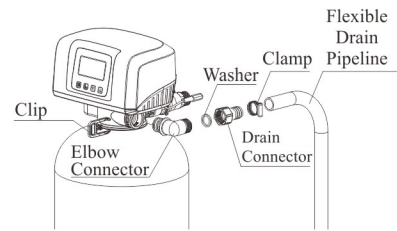

Figure 1-E

Note:

● Be sure not connect drain with sewer directly, and leave 15-25mm between them (As the Figure 1-F shows), avoid wastewater being absorbed to the water treatment equipment.

⑥ Install leakage sensor

The installation of leakage sensor can be done by double sticky tape or expanding bolt. The leakage sensor should be located on the ground where is near the control valve and easy to detect leakage.

a. Installation of single point of monitoring (Standard)

● Double sticky tape installation

Tears off the protective layer of the double sticky tape and fix it on the ground.

The sticking position should be dry and clean.

● Expanding bolt installation

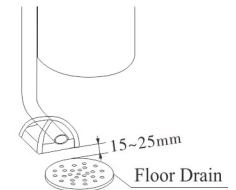
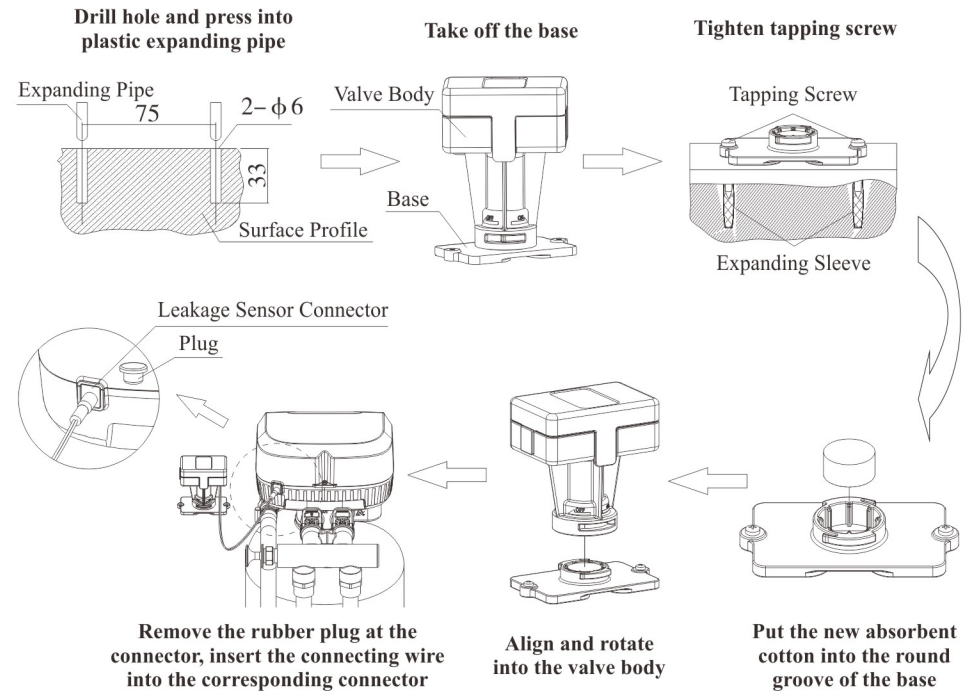
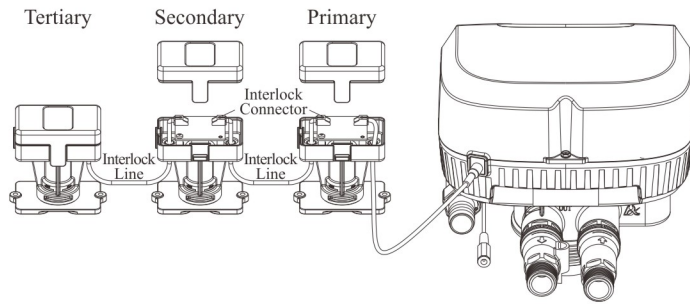

Figure 1-F



b. Installation of multi-points monitoring (Optional)

The installation of multi-points monitoring refers to the installation of single point of monitoring. Connect the pipeline as follows:



Note:

●Control valve will always be closed once the absorbent cotton of leakage sensor absorbs water. It will continue monitoring until change a new cotton, press and hold the button to restore the valve.

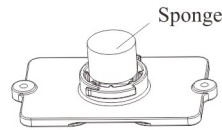

2.Basic Setting & Usage

2.1.The Function of PC Board

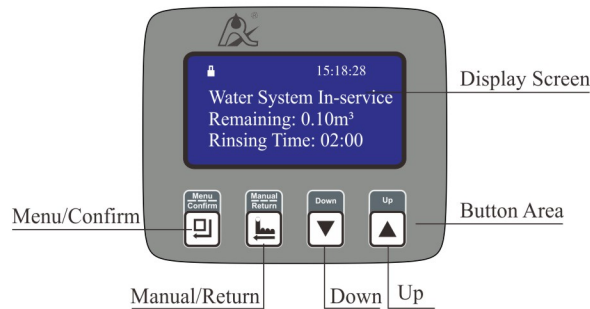

A. Button lock indicator

● lights on, which indicates the buttons are locked. At this moment, it is useless to press any single button. (Under any status, no operation in one minute, will light on and lock the buttons)

●Solution: Press and hold both and for 5 seconds until the lights off.

B. Menu/Confirm Button

●In working condition, press to enter program display mode.

●In program display mode, press to enter program set mode and adjust values.

●Press after all setting are successful and return program display mode.

C. Manual/Return Button

●Press in working conditions, it can proceed to next status. (Example: when the outlet

water fails to reach the requirement, you can press to end the service and start an immediate backwash. During the process of backwash, pressing the button can end backwash in advance and proceed to the next status.)

●Press in program display mode, and it will return to service.

●Press while adjusting the value, then it will return program display mode directly without saving value.

D.Down and Up

●In program display mode, press or to view all values.

●In program set mode, press or to adjust values.

●Press and hold both and for 5 seconds to unlock the buttons.

●At service status, press for 5 seconds, it will enter close status. (Only execute effectively at this status)

●At close status, press for 5 seconds, it will enter service status.

2.2.Basic Setting & Usage

A.Parameter specification

Item	Parameter Set Range	Factory Default	Remark
Time of Day	00:00~23:59	Time of Day	
Rinsing Time	00:00~23:59	02:00	
Chlorine Content	0.1~10mg/L	1mg/L	
Continuous Water Time	00~120min. (This function is useless if the continuous time is set 0.)	00	If the actual continuous water time is longer than the set value, the control valve will turn to close status automatically. As shown in Figure 2-F.
Peak Flow Rate for Close	0.00~10.00m³/h (This function is useless if the peak flow rate for close is set 0.)	0.00	If the actual flow rate exceeds the set value, the control valve will turn to close status automatically. As shown in Figure 2-F.

Note:

●The display screen shows model F67N when connected with power. (F67M also shows F67N)

●After connecting power within 6 seconds, press and hold and for 2 seconds to enter into language selection interface.

B.Process display

①User usage interface

The display screen shows Figure 2-A for 6 seconds when connected with power, and enter into user usage interface.

F67N

2-A

② Working status:

12:30:25
Water System: In-service
Remaining: 7.00m³
Cur. F. R.: 3.00 m³/h

2-B1

12:30:25
Water System: In-service
Remaining: 7.00m³
Regen. Time: 02:00

2-B2

02:01:30
Water System
Backwashing.....
Remaining: 2 min.

2-C

02:03:30
Water System
Fast Rinsing
Remaining: 3 min.

2-D

Motor Running.....

2-E

12:35:00
Water System is closing.....
After unlock, press ▼
key for 5 seconds to
service status.

2-F

- The screen show circulatory figure 2-B1 and 2-B2 at the service status.
- The screen shows Figure 2-C at the backwash status.
- The screen shows Figure 2-D at the fast rinse status.
- When control valve turns from a working status to another, the screen shows Figure 2-E.
- The screen shows as Figure 2-F at the closing status.

Working process: Service → Backwash → Fast Rinse → Service

C. User setting

① Setting items and methods

Items	Process steps	Symbol
Time of Day	<p>☑ lights on, press and hold ▼ and ▲ buttons for 5 seconds until ☑ lights off.</p> <p>1. Press [Enter] to enter “Set Filter Valve Parameter”, as figure 2-G shows. The option of “Set Time of Day” will be selected by system automatically.</p> <p>2. Press [Enter], the screen shows as figure 2-H. Hour value 12 flashes, through ▼ or ▲ to adjust the hour value;</p> <p>3. Press [Enter] again, minute value 30 flashes, through ▼ or ▲ to adjust the minute value;</p> <p>4. Press [Enter], and then finish adjustment.</p>	<div style="border: 1px solid black; padding: 5px; margin-bottom: 10px;"> Set Filter Valve Para. » Set Time of Day Set Rinsing Time Chlorine Content Cont. Water Time Peak F. R. for Close </div> <p style="text-align: center;">2-G</p> <div style="border: 1px solid black; padding: 5px; margin-bottom: 10px;"> Set Time of Day 12:30 </div> <p style="text-align: center;">2-H</p>

Rinsing Time	<p>1. Press [Enter] to enter “Set Filter Valve Parameter”, as figure 2-G shows.</p> <p>2. Press ▼, select “Set Rinsing Time”; Then press [Enter], the screen shows as figure 2-I; Hour value 02 flashes, through ▼ or ▲ to adjust the hour value;</p> <p>3. Press [Enter], minute value 00 flashes, through ▼ or ▲ to adjust the minute value.</p> <p>4. Press [Enter], and then finish adjustment.</p>	<div style="border: 1px solid black; padding: 5px; margin-bottom: 10px;"> Set Rinsing Time 02:00 </div> <p style="text-align: center;">2-I</p>
Chlorine Content	<p>1. Press [Enter] to enter “Set Filter Valve Parameter”, as figure 2-G shows.</p> <p>2. Press ▼, select “Chlorine Content”; Then press [Enter], the screen shows as figure 2-J; The value 1.0 flashes, through ▼ or ▲ to adjust the value;</p> <p>3. Press [Enter], and then finish adjustment.</p>	<div style="border: 1px solid black; padding: 5px; margin-bottom: 10px;"> Chlorine Content 1.0 mg/L </div> <p style="text-align: center;">2-J</p>
Continuous Water Time	<p>1. Press [Enter] to enter “Set Filter Valve Parameter”, as figure 2-G shows.</p> <p>2. Press ▼, select “Cont. Water Time”; Then press [Enter], the screen shows as figure 2-K; Minute value 00 flashes, through ▼ or ▲ to adjust the minute value;</p> <p>3. Press [Enter], and then finish adjustment.</p>	<div style="border: 1px solid black; padding: 5px; margin-bottom: 10px;"> Cont. Water Time 00 min. </div> <p style="text-align: center;">2-K</p>
Peak Flow Rate for Close	<p>1. Press [Enter] to enter “Set Filter Valve Parameter”, as figure 2-G shows.</p> <p>2. Press ▼, select “Peak F. R. for Close”; Then press [Enter], the screen shows as figure 2-L; peak flow rate for close value 0.00 flashes, through ▼ or ▲ to adjust it;</p> <p>3. Press [Enter], and then finish adjustment.</p>	<div style="border: 1px solid black; padding: 5px; margin-bottom: 10px;"> Peak F. R. for Close 0.00 m³/h </div> <p style="text-align: center;">2-L</p>

D.WIFI operation manual

APP QR code of "Water device"

- ① Firstly, use cell phone browser to scan Figure 2-M QR code, select proper APP to download (for iPhone, it could enter "Water device" in App Store to download).
- ② If installation is successfully, there is a "Water device" APP on cell phone interface. Then open it, register and login to configure the cell phone with device.
- ③ The configuration process is shown as following.



Figure 2-M

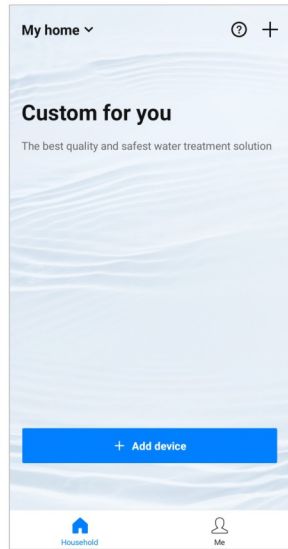

Figure 2-N

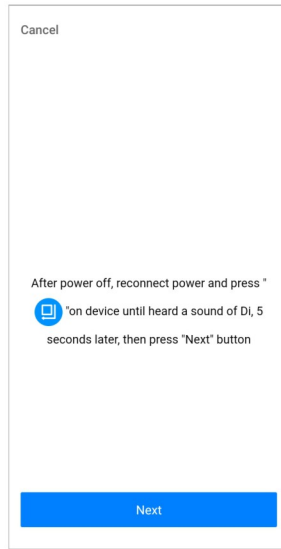

Figure 2-O

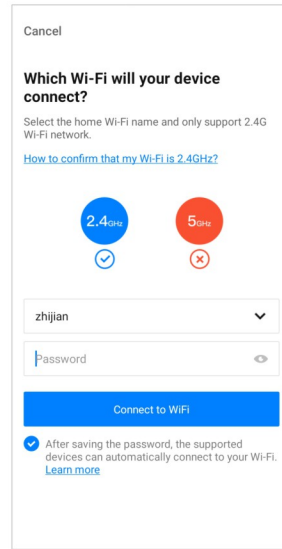
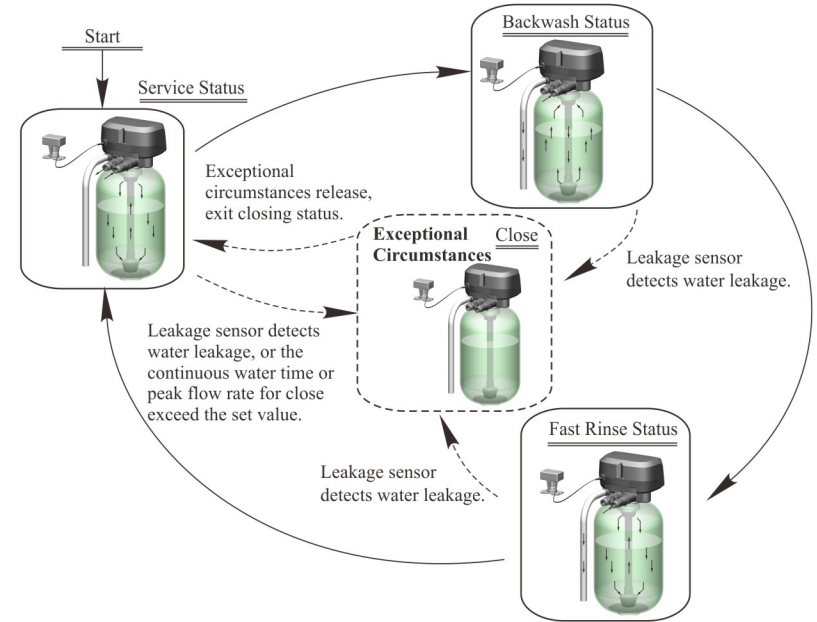

Figure 2-P

- ④ In Figure 2-N, click "Add device", enter to Figure 2-O interface. Follow the instruction, disconnect the power and reconnect it manually. Press and hold button until hear a buzzer "Di". Press "Next" after 5 seconds. Then enter to Figure 2-P interface. Input the Wi-Fi password, click "Connect to Wi-Fi" and wait for configuration. After configuration successfully, you can perform related operations such as device addition, name modification, saving data, etc.

3.Applications

3.1.Flow Chart



3.2.The Function and Connection of PC Board

Opening the front cover of control valve, you will see the main control board and connection connectors as the figure shows below.

